

5

YEARS  
PARTS

2 YEARS LABOUR

All CDA appliances are covered by a 5 year parts and 2 year labour guarantee for **complete peace of mind**.\*



|C|D|A|

Appliances | Sinks | Taps

5

YEARS  
PARTS

2 YEARS LABOUR



\*See terms and conditions for more details.

All CDA sinks and taps are covered by a 5 year parts guarantee\*. Labour/fitting costs are not included unless under exceptional circumstances.

All guarantees are subject to registration within 30 days of purchase - register online at [www.cda.eu](http://www.cda.eu) or complete the form inside your appliance.

## Contact us for more information

The Sales Team: 01949 862010

The Customer Care Team: 01949 862012

[www.cda.eu](http://www.cda.eu)

The CDA Group Ltd. Harby Road, Langar, Nottinghamshire, NG13 9HY T: 01949 862 000 F: 01949 862 001 E: [sales@cda.eu](mailto:sales@cda.eu)

Distributed in Ireland by: **Bodel Distributors**. Hulls Lane, Lisburn, BT28 2SR T: 048 9267 2412 F: 048 9267 1873 W: [www.bodel.com](http://www.bodel.com)  
Distributed in Pakistan by: **Chughtaiz**. Lahore, Pakistan T: +92 42 3578 2891 2 W: [www.chughtaiz.com](http://www.chughtaiz.com) | Part of the Amica Group

|C|D|A|

# Built for your life

## Kitchen Retail Brochure 2022

March 2022





## Why choose CDA?

### Our assurance of quality

Our on-site testing laboratory ensures that only safe, reliable products are brought to market. We test to the British consumers' exacting standards without compromise.

### Dedicated engineers

We use our own dedicated service engineers, equipped with a large range of CDA spare parts allowing them to achieve an industry-leading first time fix rate.

### Over 30 years' experience

Established for over 30 years, CDA have built a reputation for stylish, innovative and award-winning products that consistently deliver outstanding results.

### Part of the Amica Group PLC

In December 2015, CDA became part of the Amica Group. Amica, a kitchen appliance manufacturer based in Poland, operate in 50 countries worldwide and have over 70 years' experience in the industry.

### In-house customer care

Our in-house Customer Care team, based at our head office in Nottinghamshire, is made up of highly knowledgeable and experienced people who will support you throughout the lifetime of your product.

### More deliveries to you

CDA deliver directly to retailers and kitchen studios across the UK. Appliances are carefully picked and loaded from our own warehousing facilities to get them on the road to you as quickly as possible.

### ISO9001 accredited

CDA have achieved ISO9001 accreditation, recognising our commitment to continuous improvement.

**Amica**  
for living



FS 532687



“Quality is something we respect and strive for in our products, our people and our service.

Our reputation is built on delivering genuine quality through those three foundations every single day.”

Ian Kershaw  
CDA founder and Chairman

# Contents

## COOKING

Single ovens	9
Compacts	19
Double ovens	29
Hobs	33
Gas hobs	39
Electric hobs	49
Extractors	61

## COOLING

Refrigeration	77
Wine coolers	93

## WASHING

Dishwashers	101
Laundry	107

## SINKS AND TAPS

Sinks	113
Taps	147

## ACCESSORIES 161

# Oven functions explained

Our ovens come with a wide selection of functions to help you cook your meal to perfection every time.



## Oven light

This illuminates the oven cavity for easy viewing of food during cooking.



## Defrost

Using the fan only, this oven function circulates the air around the oven cavity, speeding up the natural defrosting process.



## Conventional oven/ Eco conventional oven

This function uses the top and bottom heating elements only. Natural convection creates a perfect cooking zone in the centre of the oven, ideal for dark fruit cakes and pastries.

The Eco setting on the fan oven or conventional oven uses residual heat to finish cooking your meal, saving energy.



## Fan oven/Eco fan oven

Using the circular heating element and the fan, this cooking function circulates heated air around the oven cavity; temperatures are achieved quickly reducing the need for preheating. Both cooking temperature and cooking time can be reduced for a more energy-efficient cooking programme. This is perfect for cooking various food types simultaneously as foods are sealed quickly to prevent flavour transfer.

The Eco setting on the fan oven or conventional oven uses residual heat to finish cooking your meal, saving energy.



## Fan-assisted oven

Using the fan to circulate the heat produced by the top and bottom heating elements, this function distributes the heat around the oven to give an even temperature throughout.



## Fan cooking with lower heat

Using the fan element to enhance the main heat being produced by the lower heating element, this function is perfect for cooking pizzas.



## Fan cooking with upper heat

Uses the fan element and the top element to create a gentle heat, ideal for reheating already cooked foods or keeping food warm.



## Fan with lower heat

The fan circulates the heat produced by the bottom heating element, ideal for one-pot dishes such as casseroles or curries.



## Browning oven

The perfect finishing touch. Using the top element only, this function browns and crisps food with conventional heat. This is ideal for cauliflower or macaroni cheese.



## Warming oven

Using heat produced only by the bottom element, this natural heat is perfect for proving dough and blind baking.



## Steam clean

Use this cleaning function to harness the natural power of steam and loosen dirt and grease from your oven cavity, without the use of harsh chemicals.



## Full grill/Half grill

This fully variable grill is ideal for grilling a full family meal.

Selected ovens offer a half grill option, using just the centre section for grilling smaller quantities.



## Fanned electric grill/Fanned half electric grill

This uses the grill element and the fan to circulate the heat around the food.

Selected ovens offer a half fanned grill option, using just the centre section for grilling smaller quantities.



## Steam cooking

Cooking with the power of steam alone locks more nutrients into your food. Steaming is the healthier option for cooking meat, fish, vegetables and fruits.



## Pyrolytic cleaning

This function raises the temperature of your oven to 450°C, reducing any food deposits to a fine ash which can then be easily wiped away from the oven interior.

Full pyrolytic clean - 2 hours.



## Gas oven

Heat rises from the gas burner at the base of the oven. This method of cooking (hot at the bottom, cooler at the top) is perfect for family meals, as foods can be cooked at different temperatures at the same time.



## Rapid preheat

Select the Rapid Preheat function to boost power to your oven and bring it up to temperature in under 5 minutes.



## Gas grill

This variable gas grill is used with the door ajar, giving you perfect results when grilling chops, burgers and sausages.



## Fanned gas oven

Heat rises from the gas burner at the base of the oven and is distributed by a fan, creating an even cooking temperature.



## Microwave function

Food is cooked from the outside in using microwaves, making this style of cooking quick and convenient.



## Microwave and grill

Food is cooked from the outside in using microwaves with the added feature of the grill browning the food.



## Microwave and fan oven

Food is cooked using microwaves and browned on the outside by the fan oven.



## Microwave, grill and fan oven

This function combines the microwave function and the fan oven to cook food thoroughly and brown the top for a perfect oven finish.

**5**  
YEARS  
PARTS  
2 YEARS LABOUR



## Single ovens

Our expertise in appliance manufacturing means that whichever stylish model you choose, you can be certain of high performance, advanced technology and reliability.

### Multifunction cooking

There are plenty of cooking styles to choose from aside from steam, including: a defrost setting, conventional for baking, fan-assisted and fan oven cooking, an eco-fan setting, pizza function, bottom heat, full or half grill and fanned grill.

### Full steam oven

The **SL670** features full steam cooking, has multifunctional oven function options as well as the ability to combine the best of both with its combination steam auto programmes. This helps the cook create tender meat dishes, vibrant and fresh vegetables and even rival professional bakeries with crusty loaves or beautifully risen cakes.

### Rapid preheating

Reach temperatures of 150°C in just 4 minutes with the rapid preheating available on most models.

### Signature aesthetics

Our signature aesthetic is carried throughout the range with updated steel accents, white LED displays and a 96mm control panel. This brings the collection to the foreground of kitchen appliance design.

### Lateral lighting

Side lighting in the oven cavity features throughout the new oven range. We find that it is still the best style and positioning for providing the best cooking illumination.

### Soft close doors

The soft close action brings a high quality feel to the day to day experience of using these ovens. The attention to detail here demonstrates the thought and design that has gone into other aspects of the technology that runs through the whole range.

# Quick guide to single ovens

The CDA range offers a wide choice of designs. Each oven has an energy rating of A, alongside built-in safety features, including anti-tilt shelving to reduce accidents when removing hot food from the oven.



## More space

Products with the icon above have an extra-large cavity with a net capacity of 77L. Extra space and additional shelf positions mean you can achieve better cooking results even with a full oven.



## Self-cleaning

Our **pyrolytic oven** range has a self-cleaning programme that enables the oven to clean itself.

The programme automatically locks the oven door for safety, then heats the internal oven cavity to over 450°C to incinerate residual cooking fat and spills to a fine ash. You can then simply wipe the ash away once the cycle has finished. Each cycle costs around 45p - much cheaper than branded oven cleaners.

## Single ovens



### SG120

- Five function gas oven
- 56L net capacity
- Details on [p13](#)



### SC621

- Seven function electric side opening oven
- 59L net capacity
- Details on [p13](#)



### SL100

- Seven function electric fan oven
- 77L net capacity
- Details on [p14](#)



### SL200

- Seven function electric fan oven
- 77L net capacity
- Details on [p14](#)



### SL300

- Twelve function multifunction oven
- 77L net capacity
- Soft close
- Details on [p15](#)



### SL400

- Thirteen function multifunction oven
- 77L net capacity
- Soft close
- Catalytic liners
- Details on [p15](#)

## Single pyrolytic ovens



### SL500

- Thirteen function pyrolytic oven
- 77L net capacity
- Details on [p17](#)



### SL550

- Thirteen function pyrolytic oven
- 77L net capacity
- Soft close
- Telescopic
- Details on [p17](#)



### SL570

- Thirteen function pyrolytic oven
- 77L net capacity
- Soft close
- Telescopic
- Temperature probe
- Details on [p18](#)

## Steam oven



### SL670

- Thirteen function steam oven
- 77L net capacity
- Soft close
- Temperature probe
- Details on [p16](#)

See [pages 19-28](#) for all our matching compact appliances

## Single ovens



### SG120

Five function gas oven

#### Features

- 60 minute minder
- Interior light
- Cooling fan
- Chromed rack sides with integrated anti-tilt shelves
- Double glazed removable door with removable inner glass for easy cleaning
- Flame failure safety device included
- Easy clean enamel interior

#### Accessories

- 2 flat oven shelves
- 1 grill pan with grid
- LPG conversion kit included

Available in stainless steel

#### Technical specification

Rated electrical power: **60W**  
 Power supply required: **3A**  
 Total usable capacity: **56L net**  
 Rated gas input: **2.7kW**

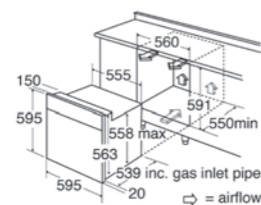

### SC621

Seven function electric side opening oven

#### Features

- Touch control programmable clock/timer
- White LED display
- Interior halogen light
- Cooling fan
- Chromed rack sides with integrated anti-tilt shelves
- Triple glazed removable cool door with removable inner glass for easy cleaning
- Reversible side opening door
- Easy clean enamel interior

#### Accessories

- 2 flat oven shelves
- 1 grill pan with grid

Available in stainless steel

Energy efficiency rating: A

#### Technical specification

Rated electrical power: **2.16kW**  
 Power supply required: **13A**  
 Total usable capacity: **59L net**

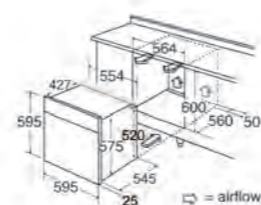

### SL100

Seven function electric fan oven

#### Features

- Offset lateral halogen lights
- Cooling fan
- Chromed rack sides with integrated anti-tilt shelves
- 6 shelf positions
- Triple glazed removable door with removable inner glass for easy cleaning
- Easy clean enamel interior

#### Accessories

- 1 easy clean flat oven shelf
- 1 space saver shelf
- 1 grill pan with grid

Available in stainless steel

Energy efficiency rating: A

#### Technical specification

Rated electrical power: **2.8kW**  
 Power supply required: **13A**  
 Total usable capacity: **77L net**

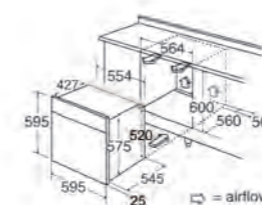

### SL200

Seven function electric fan oven

#### Features

- Touch control programmable clock/timer
- White LED display
- Offset lateral halogen lights
- Cooling fan
- Chromed rack sides with integrated anti-tilt shelves
- 6 shelf positions
- Triple glazed removable door with removable inner glass for easy cleaning
- Easy clean enamel interior

#### Accessories

- 1 easy clean flat oven shelf
- 1 space saver shelf
- 1 grill pan with grid

Available in stainless steel

Energy efficiency rating: A

#### Technical specification

Rated electrical power: **2.8kW**  
 Power supply required: **13A**  
 Total usable capacity: **77L net**

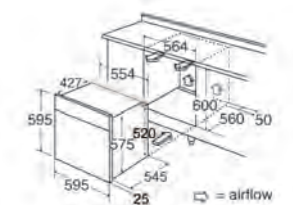



## Single ovens



Stainless steel



### SL300

Twelve function multifunction oven

#### Features

- Touch control programmable clock/timer
- White LED display
- Offset lateral halogen lights
- Cooling fan
- Chromed rack sides with integrated anti-tilt shelves
- 6 shelf positions
- Triple glazed removable door with removable inner glass for easy cleaning
- Soft close door
- Easy clean enamel interior

#### Accessories

- 1 easy clean flat oven shelf
- 1 space saver shelf
- 1 grill pan with grid
- 1 x 75% telescopic shelf

Available in stainless steel, black

Energy efficiency rating: A

#### Technical specification

Rated electrical power: **2.8kW**  
Power supply required: **13A**  
Total usable capacity: **77L net**

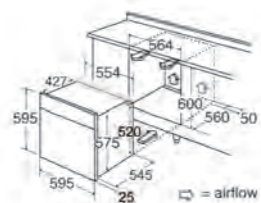

### SL400

Thirteen function multifunction oven

#### Features

- Full intuitive touch control
- White LED display
- Preset recipes
- 3pc catalytic liners
- Offset lateral halogen lights
- Cooling fan
- Safety key lock
- Chromed rack sides with integrated anti-tilt shelves
- 6 shelf positions
- Soft close door
- Triple glazed removable door with removable inner glass for easy cleaning
- Easy clean enamel interior

#### Accessories

- 1 easy clean flat oven shelf
- 1 space saver shelf
- 1 grill pan with grid
- 2 x 75% telescopic shelves

Available in stainless steel

Energy efficiency rating: A+

#### Technical specification

Rated electrical power: **2.8kW**  
Power supply required: **13A**  
Total usable capacity: **77L net**

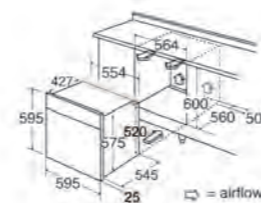

## Single pyrolytic ovens



Stainless steel



### SL500

Thirteen function pyrolytic oven

#### Features

- Touch control programmable clock/timer
- White LED display
- Pyrolytic function
- Offset lateral halogen lights
- Cooling fan
- Chromed rack sides with integrated anti-tilt shelves
- 6 shelf positions
- Quadruple glazed removable cool door with removable inner glass for easy cleaning
- Easy clean enamel interior

#### Accessories

- 1 easy clean flat oven shelf
- 1 space saver shelf
- 1 grill pan with grid

Available in stainless steel

Energy efficiency rating: A

#### Technical specification

Rated electrical power: **2.8kW**  
Power supply required: **13A**  
Total usable capacity: **77L net**

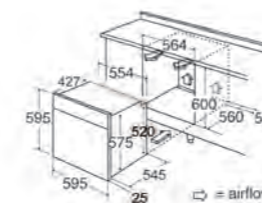

Stainless steel



### SL550

Thirteen function pyrolytic oven

#### Features

- Full intuitive touch control
- White LED display
- Pyrolytic function
- Preset recipes
- Offset lateral halogen lights
- Cooling fan
- Safety key lock
- Chromed rack sides with integrated anti-tilt shelves
- 6 shelf positions
- Soft close door
- Quadruple glazed removable door with removable inner glass for easy cleaning
- Easy clean enamel interior

#### Accessories

- 1 easy clean flat oven shelf
- 1 space saver shelf
- 1 grill pan with grid
- 2 x 75% telescopic shelves

Available in stainless steel, black

Energy efficiency rating: A+

#### Technical specification

Rated electrical power: **2.8kW**  
Power supply required: **13A**  
Total usable capacity: **77L net**

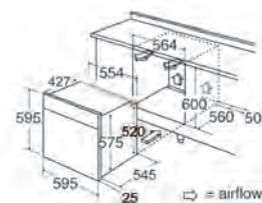

## Single pyrolytic ovens



ENERGY  
A+

Stainless steel



### SL570

Thirteen function pyrolytic oven

#### Features

- Full intuitive touch control
- White LED display
- Pyrolytic function
- Temperature probe
- Preset recipes
- Offset lateral halogen lights
- Cooling fan
- Safety key lock
- Chromed rack sides with integrated anti-tilt shelves
- 6 shelf positions
- Soft close door
- Quadruple glazed removable door with removable inner glass for easy cleaning
- Easy clean enamel interior

#### Accessories

- 1 easy clean flat oven shelf
- 1 space saver shelf
- 1 grill pan with grid
- Extra deep roasting tray
- 2 x 100% telescopic shelves

Available in stainless steel

Energy efficiency rating: A+

#### Technical specification

Rated electrical power: **2.8kW**  
Power supply required: **13A**  
Total usable capacity: **77L net**

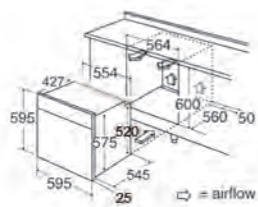

## Steam oven



ENERGY  
A+



### SL670

Thirteen function steam oven

#### Features

- Full intuitive touch control
- White LED display
- Full steam cooking
- Combination steam cooking
- Temperature probe
- Preset recipes
- 3pc catalytic liners
- Offset lateral halogen lights
- Cooling fan
- Safety key lock
- Chromed rack sides with integrated anti-tilt shelves
- 6 shelf positions
- Soft close door
- Triple glazed removable door with removable inner glass for easy cleaning
- Easy clean enamel interior

#### Accessories

- 1 easy clean flat oven shelf
- 1 space saver shelf
- 1 grill pan with grid
- Extra deep roasting tray
- 2 x 100% telescopic shelves

Available in stainless steel

Energy efficiency rating: A+

#### Technical specification

Rated electrical power: **2.8kW**  
Power supply required: **13A**  
Total usable capacity: **77L net**

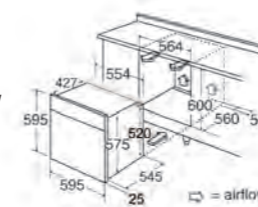

**5**  
**YEARS**  
**PARTS**  
2 YEARS LABOUR



## Compacts

In our compacts range you'll find a selection of useful and innovative appliances that add functionality and that special finishing touch to your kitchen.

### Compact coffee maker

The **VC820** automatic coffee maker will make mornings worth waking up for. This built-in 60cm coffee maker comes with full touch control and multiple grind settings, along with adjustable coffee strength and quantities. You can use coffee beans or pre-ground coffee with this machine, making it truly flexible to your lifestyle.

It's Procino function takes the hassle out of making lattes and cappuccinos. There is no need to heat and froth milk separately as this feature rolls the whole process into one, leaving you with a perfectly prepared coffee to enjoy.

### Steam cooking

Now with full touch control, the **VK703SS** offers healthy, vitamin-preserving cooking at home. The refillable reservoir means that there is no need to connect to the mains water supply and the combination grill allows you to brown food for an appetising finish.

### Drawers

A warming drawer is ideal for warming plates, proving dough, melting chocolate, making yoghurt and keeping cooked food warm. These are so useful that once you've had one you'll never want to do without!

Choose between a 'push-push' open and close action, where you press the drawer surface to make it slide open and again to close it, or a traditional ergonomic handle design to finish your kitchen.

### Compact ovens

Our compact range offers a steam oven, a compact combination and a microwave model. The **VK903** provides a grill, microwave and a fan oven all in one neat appliance, making it the perfect choice for kitchens where space is limited.

# Quick guide to compact cooking and microwaves

These versatile compact appliances look stunning when installed together as a bank. Install warming drawers beneath for ultimate cooking flexibility.

We have a choice of microwaves to suit your requirements. Choose from a range of freestanding and built-in options with a range of cooking functions.

## Microwaves

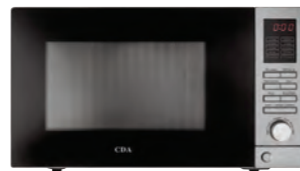

### VM101

- **Freestanding microwave oven and grill**
- LED timer and clock
- Quick start
- [Details on p23](#)



### VM201

- **Freestanding microwave oven and grill**
- LED timer and clock
- Quick start
- [Details on p23](#)



### VM131

- **Built-in microwave oven**
- LED timer and clock
- Auto defrost
- Stainless steel or black
- [Details on p24](#)



### VM231

- **Built-in microwave oven and grill**
- LED timer and clock
- Auto defrost
- Stainless steel or black
- [Details on p24](#)



### VM452

- **Built-in microwave oven, grill and convection oven**
- LED timer and clock
- Auto defrost
- Quick start
- [Details on p25](#)



### VM551

- **Wall unit microwave oven**
- LED timer and clock
- Manual and auto defrost
- Quick start
- [Details on p25](#)

## Compact appliances



### VK703

- **Compact steam oven and grill**
- Full touch control
- LED display
- [Details on p26](#)



### VK903

- **Compact combination microwave, grill and fan oven**
- Full touch control
- LED display
- [Details on p26](#)



### VC820

- **Fully automatic coffee maker**
- Procino function
- Full touch control
- Stainless steel or black
- [Details on p27](#)

## Compact refrigeration

Please see our refrigeration section for the following compact refrigeration products:

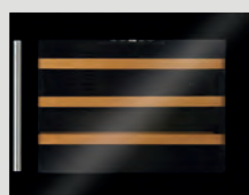

### FWV452

- Built-in compact wine cooler
- [Details on p100](#)

## Drawers



### VW143

- **Warming drawer**
- 6 place settings
- Fan heat
- Smooth runners
- [Details on p28](#)



### VW153

- **Push-push warming drawer**
- 6 place settings
- Fan heat
- Smooth runners
- Stainless steel or black
- [Details on p28](#)



## VM101

Freestanding microwave oven

### Features

- Microwave function
- Auto defrost
- Quick start
- LED timer and clock
- 5 microwave power levels - 900W max
- Interior lateral light
- Acoustic end of programme signal
- Left hand hinged door
- Safety key lock

### Accessories

- Glass turntable - 315mm diameter
- Turntable ring

Available in stainless steel

### Technical specification

Total usable capacity: **25L net**  
 Rated electrical power: **1.45kW**  
 Power supply required: **13A**

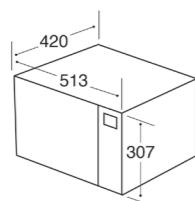

## VM201

Freestanding microwave oven and grill

### Features

- Microwave function
- Grill function
- Microwave/grill function
- Auto defrost
- Quick start
- LED timer and clock
- 5 microwave power levels - 900W max
- Grill rating - 1kW
- Interior lateral light
- Acoustic end of programme signal
- Left hand hinged door
- Safety key lock

### Accessories

- Glass turntable - 315mm diameter
- Turntable ring
- Trivet

Available in stainless steel

### Technical specification

Total usable capacity: **25L net**  
 Rated electrical power: **1.45kW**  
 Power supply required: **13A**

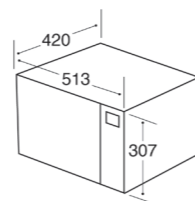

Stainless steel



Black

## VM131

Built-in microwave oven

### Features

- Microwave function
- Auto defrost
- Quick start
- LED timer and clock
- 5 microwave power levels - 900W max
- Interior lateral light
- Acoustic end of programme signal
- Left hand hinged door
- Safety key lock

### Accessories

- Glass turntable - 315mm diameter
- Turntable ring

Available in stainless steel, black

### Technical specification

Total usable capacity: **25L net**  
 Rated electrical power: **1.45kW**  
 Power supply required: **13A**

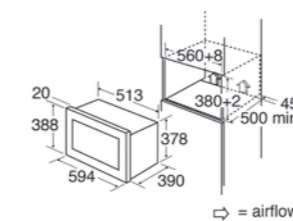

Stainless steel



Black

## VM231

Built-in microwave oven and grill

### Features

- Microwave function
- Grill function
- Microwave/grill function
- Auto defrost
- Quick start
- LED timer and clock
- 5 microwave power levels - 900W max
- Grill rating - 1kW
- Interior lateral light
- Acoustic end of programme signal
- Left hand hinged door
- Safety key lock

### Accessories

- Glass turntable - 315mm diameter
- Turntable ring
- Trivet

Available in stainless steel, black

### Technical specification

Total usable capacity: **25L net**  
 Rated electrical power: **1.45kW**  
 Power supply required: **13A**

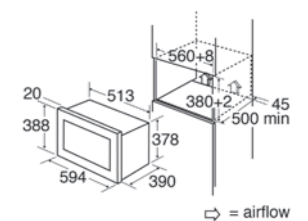

## Microwaves



### VM452

Built-in microwave oven, grill and convection oven

#### Features

- Microwave function (5 power levels - 900W max)
- Grill function (rating 1.1kW)
- Convection oven function (rating 2.5kW, maximum temperature on convection programme 220°C)
- Combination cooking functions: microwave/grill, microwave/convection, grill/convection
- Auto defrost
- 10 auto cook programmes
- Quick start
- LED timer and clock
- Interior lateral light
- Acoustic end of programme signal
- Left hand hinged door
- Safety key lock

#### Accessories

- Glass turntable - 315mm diameter
- Turntable ring
- Trivet

Available in stainless steel

#### Technical specification

Total usable capacity: **25L net**  
 Rated electrical power: **2.5kW**  
 Power supply required: **13A**

#### Fitting Notes

This microwave oven has a convection oven function but is not intended to be used as a substitute for a standard oven. Not suitable for built-under worktop fitting.

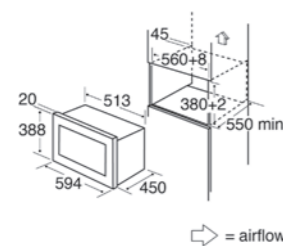

### VM551

Wall unit microwave oven

#### Features

- Microwave function
- Manual defrost
- Auto defrost
- 8 auto-cook programmes
- Quick start
- LED timer and clock
- 5 microwave power levels - 700W max
- Interior light
- Acoustic end of programme signal
- Left hand hinged door
- Safety key lock

#### Accessories

- Glass turntable - 245mm diameter
- Turntable ring

Available in stainless steel

#### Technical specification

Total usable capacity: **17L net**  
 Rated electrical power: **1.05kW**  
 Power supply required: **5A**

#### Fitting Notes

Not suitable for built-under worktop fitting.

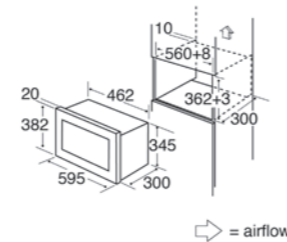

## Compact appliances



### VK703

Compact steam oven and grill

#### Features

- Full touch control
- LED display
- Interior lateral halogen light
- Stainless steel interior
- Variable temperature
- Variable grill
- Removable 1L water reservoir
- 8 auto cooking programmes
- Programmable clock/timer
- Double glazed removable door with removable inner door glass for easy cleaning
- Safety key lock

#### Accessories

- Stainless steel steam cooking set
- Trivet
- Wire shelf

Available in stainless steel

#### Technical specification

Total usable capacity: **32L net**  
 Rated electrical power: **1.3kW**  
 Power supply required: **13A**

#### Fitting Notes

Should be installed as a built-in appliance.

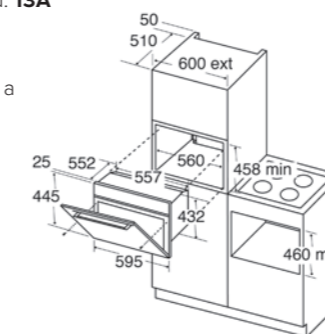

Stainless steel



Black



### VK903

Compact combination microwave, grill and fan oven

#### Features

- Full touch control
- LED display
- 6 microwave power levels - 900W max
- Interior light
- Auto defrost
- 3 auto cooking programmes
- Programmable clock/timer
- Cooling fan
- Double glazed removable door
- Safety key lock
- Acoustic end of programme signal

#### Accessories

- Wire shelf
- Glass turntable - 360mm diameter
- Turntable ring
- Trivet and grill pan

Available in stainless steel, black

#### Technical specification

Total usable capacity: **40L net**  
 Rated electrical power: **3.1kW**  
 Power supply required: **13A**

#### Fitting Notes

Should be installed as a built-in appliance.

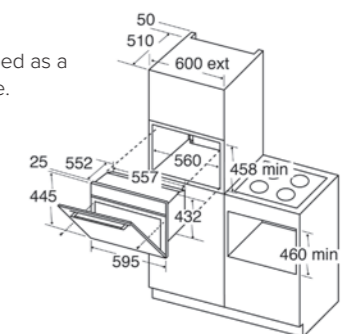

## Compact appliances



Stainless steel



Black

### VC820

Fully automatic coffee maker

#### Features

- Fully automatic
- Full touch control
- Electronic programmer with LCD display
- 5 coffee strength settings
- Steam nozzle
- One or two cups
- Compatible with ground coffee and coffee beans
- Hot water and steam
- Integral water tank: 1.8L
- Integral coffee container: 0.2kg
- Low coffee warning
- Low water warning
- Removable drip tray
- Adjustable grind setting
- Integrated coffee grinder
- Procino - automatic latte and cappuccino
- 5 cup sizes
- 3 temperature settings

Available in stainless steel, black

#### Technical specification

Rated electrical power: **1.35kW**  
 Power supply required: **13A**  
 Pump pressure: **15Bar**

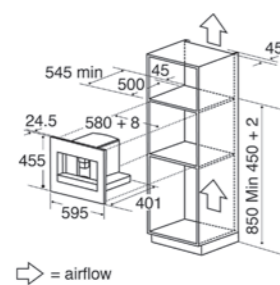

## Drawers



Stainless steel



Stainless steel



Black

### VW143

Warming drawer

#### Features

- Fan heat
- Temperature adjustable from 40° to 80°C
- 6 place settings
- Smooth runners
- Power indicator light

Available in stainless steel

#### Technical specification

Rated electrical power: **0.44kW max**  
 Power supply required: **3A**  
 Maximum capacity: **20kg**

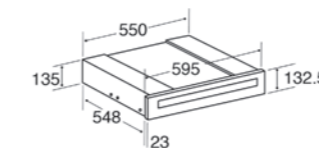

### VW153

Push-push warming drawer

#### Features

- Fan heat
- Temperature adjustable from 40° to 80°C
- 6 place settings
- Smooth runners
- Power indicator light
- Push-push opening

Available in stainless steel, black

#### Technical specification

Rated electrical power: **0.44kW max**  
 Power supply required: **3A**  
 Maximum capacity: **20kg**

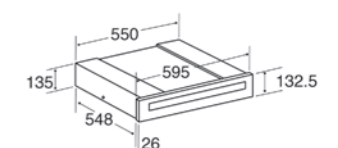

**5**  
YEARS  
PARTS  
2 YEARS LABOUR



Double ovens

## Double ovens

Available in both built-in and built-under options, our A-rated double ovens offer a winning combination of extra cooking space and outstanding features.

### Generous capacity

Choose between the **DC741** and **DC941** for useful extra cooking space at either an under-counter or eye-level height with built-under and built-in options. Design your cooking space around you.

Our built-under **DC741SS** integrated double oven features a full-sized main oven cavity and a second, slightly smaller conventional oven cavity. It is designed to be installed directly underneath your work surface. This is ideal if you have an open plan kitchen or your kitchen predominantly uses lower-level units in its design enabling you to keep the eye line clear throughout the space.

The **DC941SS** built-in double oven is installed off the floor, at eye-level to give you convenient access to both oven cavities.

### Energy Efficient

Our double ovens have excellent energy ratings to make sure that you can be kind to the environment and get the best value for money at home with reduced energy bills. Even the internal halogen lighting inside of our double ovens is bright and efficient for practicality and energy efficiency.

### Simultaneous cooking

Both styles of double oven offer you a lot of convenience and flexibility when cooking. You can easily cook dishes at different temperatures, keep food and plates warm, or even prepare an entirely separate course simultaneously.



# Quick guide to double ovens

Choose from either a built-in double oven, for eye-level cooking, or a built-under model that fits beneath your worktop and makes the most of your low level space.

All our double ovens are A-rated in both oven cavities.

## Built-under double oven



### DC741

- **Built-under electric double oven**
  - Touch control programmable electronic clock/timer
  - Easy clean enamel interior
  - Available in stainless steel and black
- [Details on p32](#)

## Built-in double oven



### DC941

- **Built-in electric double oven**
  - Touch control programmable electronic clock/timer
  - Easy clean enamel interior
  - Available in stainless steel and black
- [Details on p32](#)

## Built-under double oven



Top oven



Main oven



### DC741

Built-under electric double oven

#### Features

- Touch control programmable electronic clock/timer
- Easy clean enamel interior
- Interior halogen lights
- Cooling fan
- Chromed rack sides with integrated anti-tilt shelves
- Double glazed removable doors with removable inner glass for easy cleaning

#### Accessories

- Grill pan with grid
- 3 flat oven shelves

Available in stainless steel, black

#### Technical specification

Top oven usable capacity: **35L net**  
 Main oven usable capacity: **50L net**  
 Rated electrical power: **4.3kW**  
 Power supply required: **20A**

#### Fitting Notes

Please ensure you check that there is sufficient clearance above built-under ovens when fitting the relevant hob.

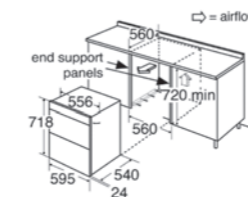

## Built-in double oven



Top oven



Main oven



### DC941

Built-in electric double oven

#### Features

- Touch control programmable electronic clock/timer
- Easy clean enamel interior
- Interior halogen lights
- Cooling fan
- Chromed rack sides with integrated anti-tilt shelves
- Double glazed removable doors with removable inner glass for easy cleaning

#### Accessories

- Grill pan with grid
- 3 flat oven shelves

Available in stainless steel, black

#### Technical specification

Top oven usable capacity: **35L net**  
 Main oven usable capacity: **59L net**  
 Rated electrical power: **4.3kW**  
 Power supply required: **20A**

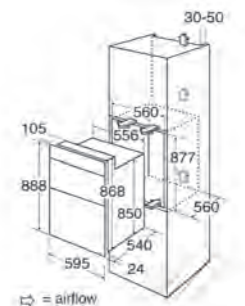

**5**  
**YEARS**  
**PARTS**  
2 YEARS LABOUR



## Hobs

Everyone has their preference, and we offer everything from bridging induction hobs to professional-style gas hobs in sizes from domino to extra-wide.

### Gas hobs

From practical four burner models to huge six burner hobs, we cater for every type of cook. Wok burners give you maximum power when you need it and additional wok supports allow you to get creative with your cooking.

### Ceramic hobs

Our ceramic hob range is a practical option for those wanting an easy-to-clean cooking area. The resistant ceramic glass material is ideal for households where a quick wipe over after cooking is all you have time for.

### Induction hobs

Induction hobs reach temperature quickly and reduce the energy losses associated with heat escaping. Choose induction for quicker cooking, an easy-to-clean hob surface and precision control.

If choosing this option, ensure you use compatible ferromagnetic pans. High quality, flat-based pans work best with induction hobs, and new pans will carry a symbol on the packaging to show they are compatible.

### Schott Ceran glass **SCHOTT CERAN®**

Some CDA hobs feature Schott Ceran® glass, an extremely stable material that is resistant against abrupt temperature changes, making it capable of withstanding the daily wear and tear of a frequently-used kitchen.

The four-millimetre-thick glass is extremely heat-permeable, and is able to transfer heat quickly and efficiently so that it is transmitted directly to the pots and pans, keeping the rest of the hob relatively cool. This makes it both safe and energy efficient. Glass-ceramic is the only material suitable for all kinds of heating technologies - ceramic, induction and gas.

# Quick guide to gas hobs

Our range of gas hobs offers a wide choice. This comprehensive collection includes 1 and 2 burner domino hobs, functional 4 burner hobs and stunning 5 and 6 burner hobs for the most professional kitchen.

We have included beautiful, solid cast iron pan supports as standard with most of our hobs, whilst the **HCG302**, **HG6151** and **HG6251** have enamelled pan supports if you prefer a dishwasher-friendly option.

## Gas hobs



### HCG302

- Two burners
- Enamel pan support
- Front control

Details on [p40](#)



### HG6151

- Four burners
- Enamel pan support
- Side control

Details on [p40](#)



### HG6251

- Four burners
- Enamel pan support
- Front control
- Wok burner
- Stainless steel or black

Details on [p41](#)



### HG6351

- Four burners
- Cast iron pan support
- Front control
- Wok burner

Details on [p41](#)

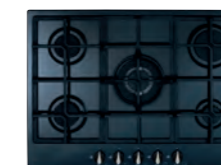

### HG7251

- Five burners
- Cast iron pan support
- Front control
- Wok burner

Details on [p42](#)



### HG7351

- Five burners
- Cast iron pan support
- Front control
- Wok burner

Details on [p42](#)



### HG7501

- Four burners
- Cast iron pan supports
- Front control
- 2 wok burners (1 dual control)

Details on [p43](#)



### HG9351

- Five burners
- Cast iron pan supports
- Front control
- Wok burner

Details on [p43](#)



### HG9321

- Six burners
- Cast iron pan supports
- Wok burner
- Side control

Details on [p44](#)

## Gas-on-glass hobs



### HG3610

- Domino single burner gas on glass
- Front control
- Cast iron pan supports

Details on [p45](#)



### HG3620

- Domino two burner gas on glass
- Front control
- Cast iron pan supports

Details on [p45](#)

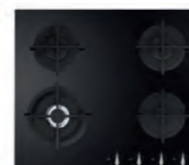

### HVG671

- Four burner gas on glass
- Front control
- Cast iron pan supports

Details on [p47](#)

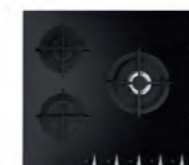

### HVG781

- Five burner gas on glass
- Front control
- Cast iron pan supports

Details on [p47](#)



### HVG971

- Five burner gas on glass
- Front control
- Cast iron pan supports

Details on [p48](#)



### HVG621

- Four burner gas on glass
- Front control
- Cast iron pan supports

Details on [p46](#)



### HVG721

- Five burner gas on glass hob
- Front control
- Cast iron pan supports

Details on [p46](#)



All CDA gas hobs have automatic ignition and a flame failure safety device 'Flame Safe' as standard.

Flame Safe is a feature designed to close off the gas supply in the event that a burner is accidentally extinguished.

# Quick guide to electric hobs

Our range of electric hobs includes a comprehensive selection of both manual and touch control 2, 4 and 5 zone ceramic hobs, high-tech induction hobs and domino hobs which you can put together in different combinations to suit your requirements.

All CDA ceramic and induction hobs have easy clean surfaces, shatterproof ceramic safety glass and residual heat indicators.

## Electric



### HE3141

- Two-plate electric domino hob
- Front rotary control
- Details on [p50](#)



### HE6052

- Four-plate electric hob
- Side rotary control
- Details on [p50](#)

## Ceramic



### HC3621

- Two zone ceramic domino hob
- Front touch control
- Details on [p51](#)

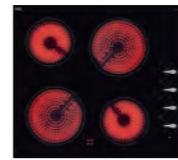

### HC6212

- Four zone ceramic hob
- Side rotary control
- Details on [p51](#)

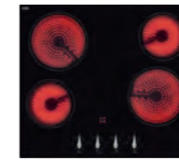

### HC6312

- Four zone ceramic hob
- Front rotary control
- Details on [p52](#)

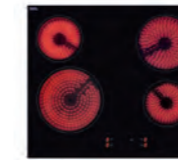

### HC6621

- Four zone ceramic hob
- Front rotary control
- Details on [p52](#)



### HC7621

- Five zone ceramic hob
- Front rotary control
- Details on [p53](#)



### HC9621

- Five zone ceramic hob
- Front rotary control
- Details on [p53](#)

## Ceramic



### HC9606

- Four zone ceramic hob
- Front touch control
- Details on [p54](#)

## Induction



### HN3621

- Two zone domino induction hob
- Induction hob
- Front touch control
- Details on [p55](#)



### HN6111

- Four zone induction hob
- Front touch control
- Details on [p55](#)



### HN6412

- Four zone induction hob
- Front touch control
- Power management system
- Details on [p56](#)



### HN6732

- Four zone induction hob
- Front touch control
- Bridging function
- Details on [p56](#)

## Induction



### HN6841

- Four zone induction hob
- Front touch control
- Bridging function
- Illuminated front edge
- Details on [p57](#)



### HN9611

- Five zone induction hob
- Front touch control
- Bridging function
- Details on [p57](#)



### HN9626

- Four zone linear induction hob
- Front touch control
- Details on [p58](#)

## Indu-Air

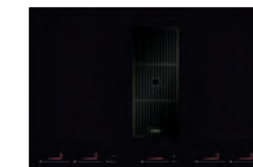

### HNE8

- Four zone induction hob with built-in extractor
- Front touch control
- Bridging function
- Details on [p59](#)



# Gas hobs

Our range includes a variety of sizes and styles to suit every kitchen, whether you're a casual cook or a dedicated dinner party chef.

## Gas hobs



### HCG302

Domino two burner gas hob



#### Features

- Front control
- Enamel pan support
- Automatic ignition
- Flame failure safety device

#### Accessories

- LPG conversion kit included

Available in stainless steel

#### Burners technical specification

Front, semi-rapid: **1.75kW**  
 Rear, rapid: **3kW**  
 Rated gas input: **4.75kW**  
 Rated electrical power: **1W**  
 Power supply required: **3A**

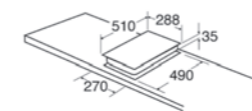

### HG6151

Four burner gas hob



#### Features

- Side control
- Enamel pan supports
- Automatic ignition
- Flame failure safety device

#### Accessories

- LPG conversion kit included

Available in stainless steel

#### Burners technical specification

Front left, rapid: **3kW**  
 Front right, auxiliary: **1kW**  
 Rear left, semi-rapid: **1.75kW**  
 Rear right, semi-rapid: **1.75kW**  
 Rated gas input: **7.5kW**  
 Rated electrical power: **1.1W**  
 Power supply required: **3A**

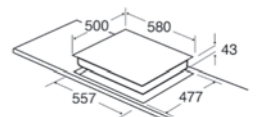

## Gas hobs



Stainless steel



Black

### HG6251

Four burner gas hob



#### Features

- Front control
- Enamel pan supports
- Automatic ignition
- Flame failure safety device
- Wok burner

#### Accessories

- LPG conversion kit included

Available in stainless steel, black

#### Burners technical specification

Front left, triple ring/wok: **3.8kW**  
 Front right, auxiliary: **1kW**  
 Rear left, semi-rapid: **1.75kW**  
 Rear right, semi-rapid: **1.75kW**  
 Rated gas input: **8.3kW**  
 Rated electrical power: **1.1W**  
 Power supply required: **3A**

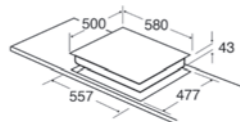

### HG6351

Four burner gas hob



#### Features

- Front control
- Cast iron pan supports
- Automatic ignition
- Flame failure safety device
- Wok burner

#### Accessories

- Wok support
- LPG conversion kit included

Available in stainless steel

#### Burners technical specification

Front left, triple ring/wok: **3.8kW**  
 Front right, auxiliary: **1kW**  
 Rear left, semi-rapid: **1.75kW**  
 Rear right, semi-rapid: **1.75kW**  
 Rated gas input: **8.3kW**  
 Rated electrical power: **1.1W**  
 Power supply required: **3A**

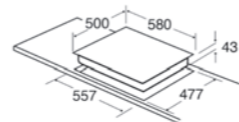

### HG7251

Five burner gas hob



#### Features

- Front control
- Cast iron pan supports
- Automatic ignition
- Flame failure safety device
- Wok burner

#### Accessories

- Wok support
- LPG conversion kit included

Available in black

#### Burners technical specification

Front left, semi-rapid: **1.75kW**  
 Front right, auxiliary: **1kW**  
 Centre, triple ring/wok: **3.8kW**  
 Rear left, semi-rapid: **1.75kW**  
 Rear right, rapid: **3kW**  
 Rated gas input: **11.3kW**  
 Rated electrical power: **2W**  
 Power supply required: **3A**

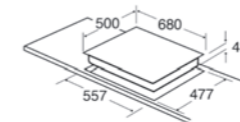

### HG7351

Five burner gas hob



#### Features

- Front control
- Cast iron pan supports
- Automatic ignition
- Flame failure safety device
- Wok burner

#### Accessories

- Wok support
- LPG conversion kit included

Available in stainless steel

#### Burners technical specification

Front left, semi-rapid: **1.75kW**  
 Front right, auxiliary: **1kW**  
 Centre, triple ring/wok: **3.8kW**  
 Rear left, semi-rapid: **1.75kW**  
 Rear right, rapid: **3kW**  
 Rated gas input: **11.3kW**  
 Rated electrical power: **2W**  
 Power supply required: **3A**

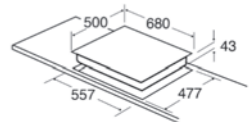



## HG7501

Four burner gas hob



### Features

- Front control
- Cast iron pan supports
- Automatic ignition
- Flame failure safety device
- 2 wok burners (1 dual control)

### Accessories

- Wok support (not shown)
- LPG conversion kit included

Available in stainless steel

### Burners technical specification

Rear central, semi-rapid: **1.75kW**  
 Right, triple ring/wok: **3.5kW**  
 Front central, auxiliary: **1kW**  
 Left, dual burner: **4.2kW**  
 Rated gas input: **10.45kW**  
 Rated electrical power: **1W**  
 Power supply required: **3A**

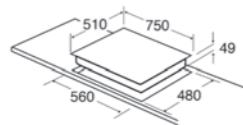

## HG9351

Five burner gas hob



### Features

- Front control
- Cast iron pan supports
- Automatic ignition
- Flame failure safety device
- Wok burner

### Accessories

- Wok support
- LPG conversion kit included

Available in stainless steel

### Burners technical specification

Front central, auxiliary: **1kW**  
 Front right, semi-rapid burner: **1.75kW**  
 Left, wok burner: **3.8kW**  
 Rear centre, rapid: **3kW**  
 Rear right, semi-rapid: **1.75kW**  
 Rated gas input: **11.3kW**  
 Rated electrical power: **2W**  
 Power supply required: **3A**

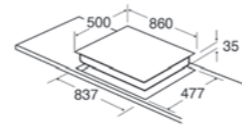

## HG9321

Six burner gas hob



### Features

- Side control
- Cast iron pan supports
- Automatic ignition
- Flame failure safety device
- Wok burner

### Accessories

- Wok support
- LPG conversion kit included

Available in stainless steel

### Burners technical specification

Front left, triple ring/wok: **3.5kW**  
 Front centre, auxiliary: **1kW**  
 Front right, auxiliary: **1kW**  
 Rear left, semi-rapid: **1.75kW**  
 Rear centre, rapid: **3kW**  
 Rear right, semi-rapid: **1.75kW**  
 Rated gas input: **12kW**  
 Rated electrical power: **1.1W**  
 Power supply required: **3A**

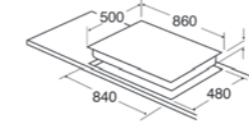

## Gas-on-glass



### HG3610

Domino single burner gas on glass

#### Features

- Front control
- Cast iron pan supports
- Automatic ignition
- Flame failure safety device
- Wok burner

#### Accessories

- Wok support (not shown)
- LPG conversion kit included

Available in black

#### Burners technical specification

Centre, triple ring/wok: **3.5kW**  
 Rated gas input: **3.5kW**  
 Rated electrical power: **1W**  
 Power supply required: **3A**

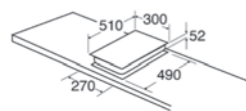

### HG3620

Domino two burner gas on glass

#### Features

- Front control
- Cast iron pan supports
- Automatic ignition
- Flame failure safety device

#### Accessories

- LPG conversion kit included

Available in black

#### Burners technical specification

Front, rapid: **3kW**  
 Rear, semi-rapid: **1.75kW**  
 Rated gas input: **4.75kW**  
 Rated electrical power: **1W**  
 Power supply required: **3A**

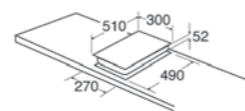

### HVG621

Four burner gas on glass

#### Features

- Front control
- Cast iron pan supports
- Automatic ignition
- Flame failure safety device
- Bevelled edges

#### Accessories

- LPG conversion kit included

Available in black

#### Burners technical specification

Front left, rapid: **3kW**  
 Front right, auxiliary: **1kW**  
 Rear left, semi-rapid: **1.75kW**  
 Rear right, semi-rapid: **1.75kW**  
 Rated gas input: **7.5kW**  
 Rated electrical power: **1.1W**  
 Power supply required: **3A**

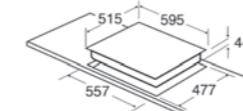

### HVG721

Five burner gas on glass

#### Features

- Front control
- Cast iron pan supports
- Automatic ignition
- Flame failure safety device
- Bevelled edges
- Wok burner

#### Accessories

- Wok support (not shown)
- LPG conversion kit included

Available in black

#### Burners technical specification

Front left, auxiliary: **1kW**  
 Front right, semi-rapid: **1.75kW**  
 Centre, wok: **3.8kW**  
 Rear left, rapid: **3kW**  
 Rear right, semi-rapid: **1.75kW**  
 Rated gas input: **11.3kW**  
 Rated electrical power: **1.1W**  
 Power supply required: **3A**

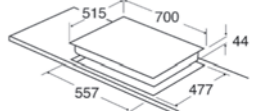



## Gas-on-glass



### HVG671

Four burner gas on glass



#### Features

- Front control
- Cast iron pan supports
- Automatic ignition
- Flame failure safety device

#### Accessories

- Wok support (not shown)
- LPG conversion kit included

Available in black

#### Burners technical specification

Front left, triple ring/wok: **3.5kW**  
 Front right, auxiliary: **1kW**  
 Rear left, rapid: **3kW**  
 Rear right, semi-rapid: **1.75kW**  
 Rated gas input: **8kW**  
 Rated electrical power: **1W**  
 Power supply required: **3A**

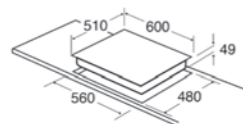

### HVG781

Five burner gas on glass



#### Features

- Front control
- Cast iron pan supports
- Automatic ignition
- Flame failure safety device
- Wok burner

#### Accessories

- Wok support (not shown)
- LPG conversion kit included

Available in black

#### Burners technical specification

Front left, rapid: **3kW**  
 Front right, auxiliary: **1kW**  
 Centre, wok: **3.5kW**  
 Rear left, rapid: **3kW**  
 Rear right, semi-rapid: **1.75kW**  
 Rated gas input: **11.3kW**  
 Rated electrical power: **1W**  
 Power supply required: **3A**

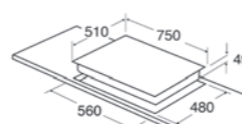

### HVG971

Five burner gas on glass



#### Features

- Front control
- Cast iron pan supports
- Automatic ignition
- Flame failure safety device
- Wok burner

#### Accessories

- Wok support (not shown)
- LPG conversion kit included

Available in black

#### Burners technical specification

Front right, rapid: **3kW**  
 Front centre, auxiliary: **1kW**  
 Left, triple ring/wok: **3.8kW**  
 Rear centre, semi-rapid: **1.75kW**  
 Rear right, semi-rapid: **1.75kW**  
 Rated gas input: **11.3kW**  
 Rated electrical power: **1W**  
 Power supply required: **3A**

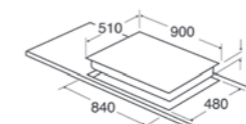



# Electric hobs

With something for everyone, our electric hob range includes domino hobs for flexibility, ceramic hobs for easy cleaning and induction hobs for fast, efficient cooking.

## Domino hobs



### HE3141

Domino two plate electric hob

#### Features

- Front control
- 6 power levels with indicator light
- 1 rapid plates

Available in stainless steel

#### Hob zones technical specification

Front, 145mm: **1kW**  
 Rear, 180mm rapid: **2kW**  
 Rated electrical power: **3kW**  
 Power supply required: **14A**

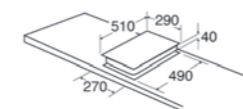

### HE6052

Four plate electric hob

#### Features

- Side control
- 6 power levels with indicator light
- 2 rapid plates

Available in stainless steel

#### Hob zones technical specification

Front left, 180mm rapid: **2kW**  
 Front right, 145mm: **1kW**  
 Rear left, 145mm rapid: **1.5kW**  
 Rear right, 180mm rapid: **1.5kW**  
 Rated electrical power: **6kW**  
 Power supply required: **30A**

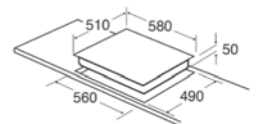

## Ceramic hobs



### HC3621

Domino two zone ceramic hob

#### Features

- Front control
- Electronic touch control
- LED display
- 9 power levels
- 99 minute timer
- Safety key lock
- Residual heat indicators
- Easy clean surface
- Ceramic shatterproof safety glass
- Overflow detection
- Overheat detection
- Auto safety switch off
- Time limit security system
- Temperature limiter

Available in black

#### Hob zones technical specification

Front, 145mm: **1.2kW**  
 Rear, 180mm: **1.8kW**  
 Rated electrical power: **3kW**  
 Power supply required: **13A**

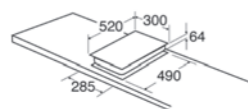

### HC6212

Four zone ceramic hob

#### Features

- Side control
- 6 power levels with indicator light
- Residual heat indicators
- Easy clean surface
- Ceramic shatterproof safety glass
- Temperature limiter

Available in black

#### Hob zones technical specification

Front left, 180mm: **1.8kW**  
 Front right, 145mm: **1.2kW**  
 Rear left, 145mm: **1.2kW**  
 Rear right, 180mm: **1.8kW**  
 Rated electrical power: **6kW**  
 Power supply required: **30A**

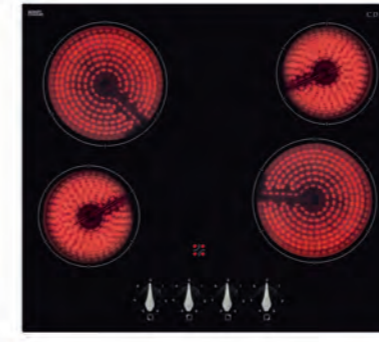
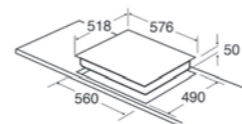

### HC6312

Four zone ceramic hob

#### Features

- Front control
- 6 power levels with indicator light
- Residual heat indicators
- Easy clean surface
- Ceramic shatterproof safety glass
- Temperature limiter

Available in black

#### Hob zones technical specification

Front left, 145mm: **1.2kW**  
 Front right, 180mm: **1.8kW**  
 Rear left, 180mm: **1.8kW**  
 Rear right, 145mm: **1.2kW**  
 Rated electrical power: **6kW**  
 Power supply required: **30A**

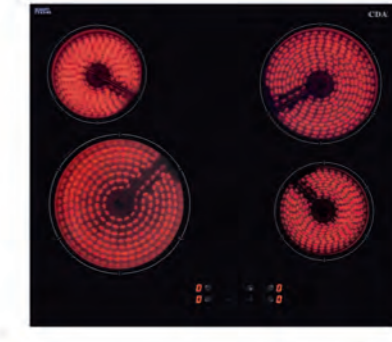
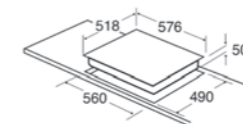

### HC6621

Four zone ceramic hob

#### Features

- Front control
- Electronic touch control
- LED display
- 9 power levels
- Safety key lock
- Residual heat indicators
- Easy clean surface
- Ceramic shatterproof safety glass
- Overflow detection
- Overheat detection
- Auto safety switch off
- Time limit security system
- Temperature limiter

Available in black

#### Hob zones technical specification

Front left, 210mm: **2.3kW**  
 Front right, 145mm: **1.2kW**  
 Rear left, 145mm: **1.2kW**  
 Rear right, 180mm: **1.8kW**  
 Rated electrical power: **6.5kW**  
 Power supply required: **30A**

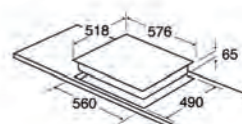

## Ceramic hobs

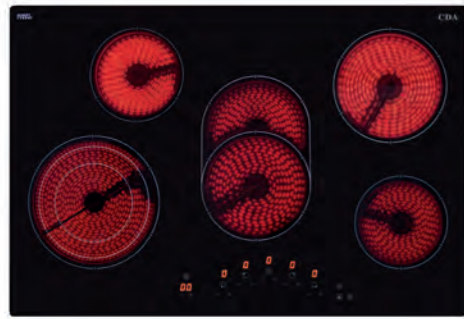

### HC7621

Five zone ceramic hob

#### Features

- Front control
- Electronic touch control
- LED display
- 9 power levels
- 99 minute timer
- Safety key lock
- Residual heat indicators
- Easy clean surface
- Ceramic shatterproof safety glass
- Overflow detection
- Overheat detection
- Auto safety switch off
- Time limit security system
- Temperature limiter

Available in black

#### Hob zones technical specification

Front left (triple), 120mm: **0.8kW**, 175mm: **1.6kW**, 210mm: **2.3kW**  
 Front right, 145mm: **1.2kW**  
 Centre (dual): 170mm: **1.5kW**, 256mm: **2.2kW**  
 Rear left, 145mm: **1.2kW**  
 Rear right, 180mm: **1.8kW**  
 Rated electrical power: **8.7kW**  
 Power supply required: **40A**

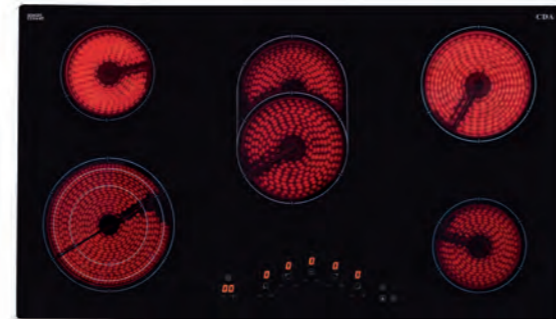
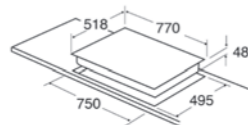

### HC9621

Five zone ceramic hob

#### Features

- Front control
- Electronic touch control
- LED display
- 9 power levels
- 99 minute timer
- Safety key lock
- Residual heat indicators
- Easy clean surface
- Ceramic shatterproof safety glass
- Overflow detection
- Overheat detection
- Auto safety switch off
- Time limit security system
- Temperature limiter

Available in black

#### Hob zones technical specification

Front left (triple), 120mm: **0.8kW**, 175mm: **1.6kW**, 210mm: **2.3kW**  
 Front right, 145mm: **1.2kW**  
 Centre (dual): 170mm: **1.5kW**, 256mm: **2.2kW**  
 Rear left, 145mm: **1.2kW**  
 Rear right, 180mm: **1.8kW**  
 Rated electrical power: **8.7kW**  
 Power supply required: **40A**

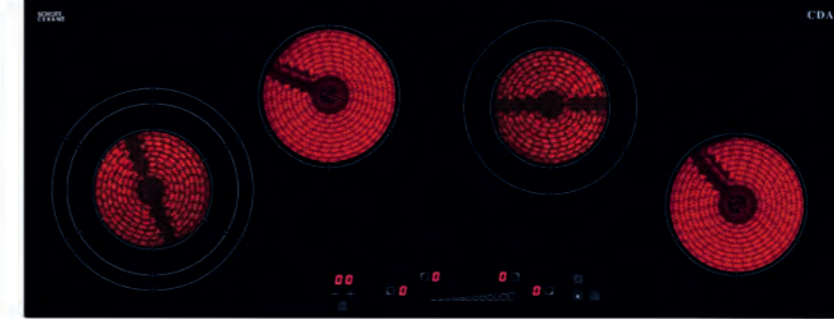
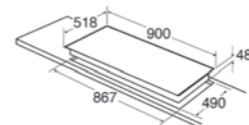

### HC9606

Four zone ceramic linear hob

#### Features

- Front control
- Electronic touch control
- LED display
- 9 power levels
- 99 minute timer
- Safety key lock
- Residual heat indicators
- Easy clean surface
- Ceramic shatterproof safety glass
- Overflow detection
- Overheat detection
- Auto safety switch off
- Time limit security system
- Temperature limiter

Available in black

#### Hob zones technical specification

Front left (triple), 120mm: **0.8kW**, 175mm: **1.6kW**, 210mm: **2.3kW**  
 Centre left, 145mm: **1.2kW**  
 Centre right (dual): 120mm: **0.7kW**, 180mm: **1.7kW**  
 Front right, 145mm: **1.2kW**  
 Rated electrical power: **6.4kW**  
 Power supply required: **30A**

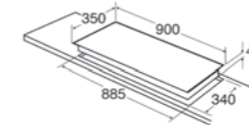

## Induction hobs



### HN3621

Domino two zone induction hob

#### Features

- Front control
- Electronic touch control
- LED display
- 9 power levels
- 99 minute timer
- Safety key lock
- Residual heat indicators
- Keep warm function
- Easy clean surface
- Ceramic shatterproof safety glass
- Overflow detection
- Overheat detection
- Automatic pan detection
- Small object detection
- Auto safety switch off
- Time limit security system
- Temperature limiter

Available in black

#### Hob zones technical specification

Front, 160mm: **1.4kW**  
 Rear, 160mm: **1.4kW**  
 Rated electrical power: **2.8kW**  
 Power supply required: **13A**

#### Fitting notes

Please ensure that you check that there is sufficient clearance when fitting induction hobs over both single and built-under double ovens and that adequate ventilation is provided.

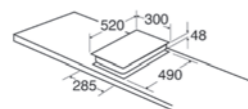

### HN6111

Four zone induction hob

#### Features

- Front control
- Electronic touch control
- LED display
- 9 power levels
- Booster function on all zones
- 99 minute timer
- Safety key lock
- Residual heat indicators
- Keep warm function
- Easy clean surface
- Ceramic shatterproof safety glass
- Overflow detection
- Overheat detection
- Automatic pan detection
- Small object detection
- Auto safety switch off
- Time limit security system
- Temperature limiter

Available in black

#### Hob zones technical specification

Front left, 210mm: **2kW**; with booster, **3kW**  
 Front right, 160mm: **1.2kW**; with booster, **1.4kW**  
 Rear left, 160mm: **1.2kW**; with booster, **1.4kW**  
 Rear right, 210mm: **2kW**; with booster, **3kW**  
 Rated electrical power: **7.4kW**  
 Power supply required: **32A**

#### Fitting notes

Please ensure that you check that there is sufficient clearance when fitting induction hobs over both single and built-under double ovens and that adequate ventilation is provided.

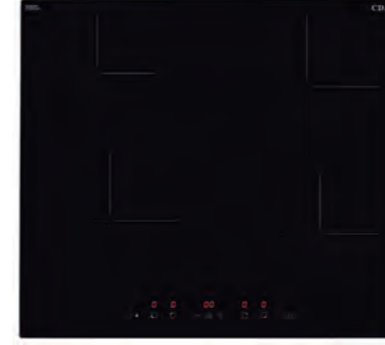
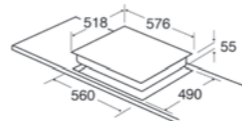

### HN6412

Four zone configurable induction hob

#### Features

- Front control
- Electronic touch control
- LED display
- 9 power levels
- Booster function on all zones
- 99 minute timer
- Safety key lock
- Residual heat indicators
- Keep warm function
- Easy clean surface
- Ceramic shatterproof safety glass
- Power management system
- Overflow detection
- Overheat detection
- Automatic pan detection
- Small object detection
- Auto safety switch off
- Time limit security system
- Temperature limiter

Available in black

#### Hob zones technical specification

Front left, 210mm: **2kW**; with booster, **2.8kW**  
 Front right, 160mm: **1.2kW**; with booster, **1.4kW**  
 Rear left, 160mm: **1.2kW**; with booster, **1.4kW**  
 Rear right, 210mm: **2kW**; with booster, **2.8kW**  
 Rated electrical power: **2.8/3.7/6/7.4kW (configurable)**  
 Power supply required: **13-32A (configurable)**

#### Fitting notes

If the hob is configured for use with a supply below 32A, the hob will automatically regulate the power consumption so as not to exceed the power available. Please ensure that you check that there is sufficient clearance when fitting induction hobs over both single and built-under double ovens and that adequate ventilation is provided.

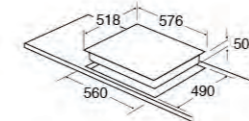

### HN6732

Four zone configurable induction hob

#### Features

- Front control
- Electronic touch control
- LED display
- 9 power levels
- Booster function on all zones
- 99 minute timer
- Safety key lock
- Residual heat indicators
- Power management system
- Pause/restart function
- Keep warm function
- Right zones bridging function
- Easy clean surface
- Ceramic shatterproof safety glass
- Overflow detection
- Overheat detection
- Automatic pan detection
- Small object detection
- Time limit security system
- Temperature limiter

Available in black

#### Hob zones technical specification

Front left, 210mm: **2kW**; with booster, **2.8kW**  
 Front right, 180mm: **1.5kW**; with booster, **2.5kW**  
 Rear left, 160mm: **1.2kW**; with booster, **1.4kW**  
 Rear right, 180mm: **1.5kW**; with booster, **2.5kW**  
 Rated electrical power: **2.8/3.7/6/7.4kW (configurable)**  
 Power supply required: **13-32A (configurable)**

#### Fitting notes

If the hob is configured for use with a supply below 32A, the hob will automatically regulate the power consumption so as not to exceed the power available. Please ensure that you check that there is sufficient clearance when fitting induction hobs over both single and built-under double ovens and that adequate ventilation is provided.

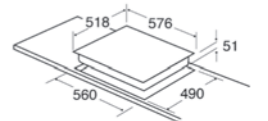

## Induction hobs



### HN6841

Four zone induction hob with illuminated front edge

#### Features

- Front control
- Electronic touch and slide control
- LED display
- 9 power levels
- Booster function on all zones
- 99 minute timer
- Safety key lock
- Residual heat indicators
- Illuminated front edge
- Pause/restart function
- Keep warm function
- Melt function
- Simmer function
- Left zones can be bridged
- Right zones can be bridged
- Side bevelled edges
- Easy clean surface
- Ceramic shatterproof safety glass
- Overflow detection
- Overheat detection
- Automatic pan detection
- Small object detection
- Auto safety switch off
- Time limit security system

Available in black

#### Hob zones technical specification

Front left, 220mm x 190mm: **2.2kW**; with booster, **3.7kW**  
 Front right, 220 x 190mm: **2.2kW**; with booster, **3.7kW**  
 Rear left: 220mm x 190mm: **2.2kW**; with booster, **3.7kW**  
 Rear right, 220 x 190mm: **2.2kW**; with booster, **3.7kW**  
 Rated electrical power: **7.4kW**  
 Power supply required: **32A**

#### Fitting notes

Please ensure that you check that there is sufficient clearance when fitting induction hobs over both single and built-under double ovens and that adequate ventilation is provided.

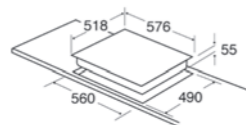

### HN9611

Five zone induction hob

#### Features

- Front control
- Electronic touch
- LED display
- 9 power levels
- Booster function on all zones
- 99 minute timer
- Safety key lock
- Residual heat indicators
- Pause/restart function
- Keep warm function
- Melt function
- Simmer function
- Easy clean surface
- Left zones bridging function
- Right zones bridging function
- Ceramic shatterproof safety glass
- Overflow detection
- Overheat detection
- Automatic pan detection
- Small object detection
- Auto safety switch off
- Time limit security system
- Temperature limiter

Available in black

#### Hob zones technical specification

Front left, 210mm: **2.1kW**; with booster, **3.7kW**  
 Front right, 210mm: **2.1kW**; with booster, **3.7kW**  
 Centre: 260mm: **2.6kW**; with booster, **3.7kW**  
 Rear left, 210mm: **2.1kW**; with booster, **3.7kW**  
 Rear right, 210mm: **2.1kW**; with booster, **3.7kW**  
 Rated electrical power: **11.1kW**  
 Power supply required: **45A**

#### Fitting notes

Please ensure that you check that there is sufficient clearance when fitting induction hobs over both single and built-under double ovens and that adequate ventilation is provided.

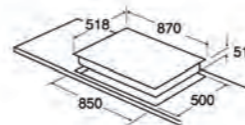

### HN9626

Four zone linear induction hob

#### Features

- Front control
- Electronic touch and slide control
- LED display
- 9 power levels
- Booster function on all zones
- 99 minute timer
- Safety key lock
- Residual heat indicators
- Pause/restart function
- Keep warm function
- Easy clean surface
- Ceramic shatterproof safety glass
- Overflow detection
- Overheat detection
- Automatic pan detection
- Small object detection
- Auto safety switch off

Available in black

#### Hob zones technical specification

Front left, 220mm: **2.3kW**; with booster, **3kW**  
 Centre left, 180mm: **1.2kW**; with booster, **1.4kW**  
 Centre right, 180mm: **1.2kW**, with booster, **1.4kW**  
 Front right, 220mm: **2.3kW**, with booster, **3kW**  
 Rated electrical power: **7.4kW**  
 Power supply required: **32A**

#### Fitting notes

Please ensure that you check that there is sufficient clearance when fitting induction hobs over both single and built-under double ovens and that adequate ventilation is provided.

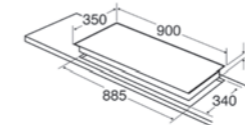

## Indu-Air hob



ENERGY  
**B**

## HNE8

Indu-Air four zone induction hob with built-in extractor

### Features

- Front control
- Electronic touch and slide control
- LED display
- 9 power levels
- Booster function on all zones
- 119 minute timer
- Safety key lock
- Residual heat indicators
- Pause/restart function
- Keep warm function
- Melt function
- Simmer function
- Left zones bridging function
- Right zones bridging function
- Easy clean surface
- Ceramic shatterproof safety glass
- Overflow detection
- Overheat detection
- Automatic pan detection
- Small object detection
- Auto safety switch off
- Time limit security system
- Temperature limiter

Available in black

### Hob zones technical specification

Front left, 220mm x 184mm: **2.1kW**; with booster, **3.7kW**  
 Front right, 220mm x 184mm: **2.1kW**; with booster, **3.7kW**  
 Rear left, 220mm x 184mm: **2.1kW**; with booster, **3.7kW**  
 Rear right, 220mm x 184mm: **2.1kW**; with booster, **3.7kW**  
 Rated electrical power: **7.4kW**  
 Power supply required: **16A x2**

### Extractor features

- Ducted/re-circulating installation
- 3 speeds + intensive
- Aluminium grease filters

### Extractor optional accessories

- Ducting kit, AED61/63/64
- Charcoal filter for re-circulation, CHA28

### Extractor technical specification

- Outlet diameter: **150mm with adaptor**
- Noise level: **67dBA**
- Extraction rate: **457m<sup>3</sup>/h**
- Rated electrical power: **168W**
- Power supply required: **3A**

Energy efficiency rating: B

### Fitting note

This appliance is not suitable for installation above an oven.

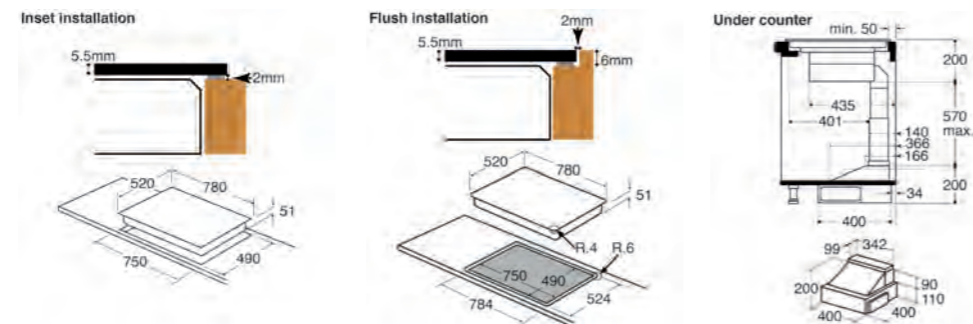

**5**  
YEARS  
PARTS  
2 YEARS LABOUR



## Extractors

As well as keeping your kitchen fresh, a stylish CDA extractor also provides a stunning focal point in the room, adding impact to the overall design.

### LED lighting

For ambient lighting in the kitchen, our range of edge-lit extractors give you the option to switch on LED lighting in a range of colours. The **EKP** range are in a curved glass design, while **EKN** models have flat glass. Both come with edge lighting detail.

For clear, ceiling-height extraction and bright LED lighting, take a look at the **EVX90** and **EVS90**. The **EVX** models come with stunning lighting and great extraction rates. Our **EVS** has 14 LED stars in the extractor surface that light up your ceiling space.

### Design

Our range of extractors offer a choice of fitting styles and finishes that will perfectly complement your kitchen. Built using the highest quality steel, glass and aluminium, the extractor collection features sharp lines and elegant curves whilst offering quiet, powerful air filtration in the kitchen.

Choose from discreet ceiling editions that are installed out of view and are controlled remotely, or downdrafts that slip quietly away beneath your work surfaces.

### Ducted

Choose between ducting your extractor outside or recirculating filtered, cleaned air back into your kitchen. We provide a comprehensive range of ducting kits and charcoal filters, listed on our accessories pages, to support your preference.

### Clean air function

The clean air function turns your extractor on for ten minutes every hour, outside of use during cooking. In these ten minutes the extractor works to purify the air in your kitchen, meaning it is not just a companion for your hob; it even works hard when you're not cooking.



# Quick guide to extractors

Our extensive range of extractors includes integrated and under-canopy models, together with a great selection of stylish, contemporary chimney and island extractors. Most CDA extractor models have dishwasher-friendly aluminium grease filters.

## Extraction and noise level measurements

The extraction rate and noise level measurements are displayed in accordance with **EN61591** for extraction rates and **EN60704** for noise levels. These measurements provide an approximation of real-world performance when installed with recommended ducting kits.

## Required distance between hob and extractor

Please refer to both your hob and extractor instructions before installation - for legal requirements, the distance between your hob and extractor should be determined by the maximum measurement provided.

## Ducting advice

Using ducting of smaller diameter than that recommended may increase the noise level and can reduce the efficiency of your extractor. Where possible, always use the largest diameter ducting you can.

### Functional



**CST61**  
• Standard extractor  
Details on [p65](#)



**EIN60**  
• Integrated extractor  
Details on [p65](#)



**CCA52/72**  
• Canopy extractor  
Details on [p66](#)



**CTE61**  
• Telescopic extractor  
Details on [p67](#)



**CTE9**  
• Telescopic extractor  
Details on [p67](#)

### Chimney



**ECH61/71/91/101**  
• Chimney extractor  
Details on [p68](#)



**ECP62/72/82/92/102/112**  
• Curved glass extractor  
Details on [p68](#)

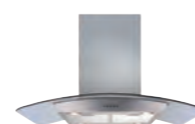

**ECPK90**  
• Curved glass island extractor  
Details on [p69](#)



**EKP60/70/90**  
• Curved glass island extractor with edge lighting  
Details on [p69](#)



**EKP60/70/90**  
• Curved glass island extractor with edge lighting  
Details on [p70](#)



**ECN62/72/92**  
• Flat glass extractor  
Details on [p70](#)



**ECNK90**  
• Flat glass island extractor  
Details on [p71](#)



**EKN60/70/90**  
• Flat glass island extractor with edge lighting  
Details on [p71](#)

### Linear



**EVP61/91/101/121**  
• Linear extractor  
Details on [p72](#)



**EVPK90**  
• Linear island extractor  
Details on [p72](#)

### Angled



**EVA60/70/90**  
• Angled extractor  
Details on [p73](#)



**EVG6**  
• Angled extractor  
Details on [p73](#)

### Gesture



**EXG60/90**  
• Gesture control angled extractor  
Details on [p74](#)

### Statement



**EVQ71**  
• Circular extractor  
Details on [p74](#)

### Ceiling



**EVX90**  
• Ceiling extractor  
Details on [p75](#)



**EVS90**  
• Ceiling extractor  
Details on [p75](#)

### Downdraft



**EDD62/92**  
• Downdraft extractor  
Details on [p76](#)

## Functional extractors



Stainless steel



White

### CST61

Standard extractor

#### Features

- Ducted/re-circulating installation
- 3 speeds
- Push button control
- Aluminium grease filter
- 1 x 5.5W LED light
- Glass light diffuser

#### Optional accessories

- Ducting kit, AED510/560
- Charcoal filter for re-circulation, CHA36 (pack of 1)

Available in stainless steel, white

Energy efficiency rating: C

#### Technical specification

Required height over gas hob: **700mm (min)**  
 Required height over electric hob: **600mm (min)**  
 Outlet diameter: **120mm**  
 Noise level: **68dBA**  
 Extraction rate: **193m<sup>3</sup>/h**  
 Rated electrical power: **70W**  
 Power supply required: **3A**

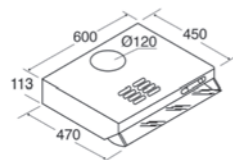

### EIN60

Integrated extractor

#### Features

- Ducted/re-circulating installation
- 3 speeds
- Slider control
- 1 x 4W LED light

#### Optional accessories

- Ducting kit, AED510/560
- Charcoal filter for re-circulation, CHA15 (pack of 1)
- Aluminium grease filter, GRE3M
- Acrylic grease filter, GRE1

Available in silver - with aluminium grease filter, EIN60FSI

Energy efficiency rating: B

#### Technical specification

Required height over gas hob: **700mm (min)**  
 Required height over electric hob: **600mm (min)**  
 Outlet diameter: **120mm**  
 Noise level: **62dBA**  
 Extraction rate: **193m<sup>3</sup>/h**  
 Rated electrical power: **49W**  
 Power supply required: **3A**

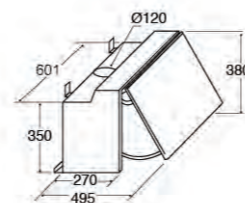

Silver



White

### CCA52/72

Canopy extractor

CCA52: 50cm wide/ CCA72: 70cm wide

#### Features

- Ducted/re-circulating installation
- 3 speeds
- Push button control
- Aluminium grease filter
- 2 x 2W LED lights

#### Optional accessories

- Ducting kit, AED510/560
- Charcoal filter for re-circulation, CHA15 (pack of 1)

CCA52 available in silver or white, CCA72 available in silver

Energy efficiency rating: B

#### Technical specification

Required height over gas hob: **700mm (min)**  
 Required height over electric hob: **600mm (min)**  
 Outlet diameter: **120mm**  
 Noise level: **63dBA**  
 Extraction rate: **206m<sup>3</sup>/h**  
 Rated electrical power: **44W**  
 Power supply required: **3A**

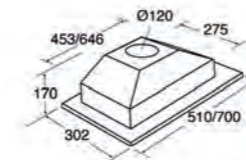

## Functional extractors



Open



Closed

### CTE61

Telescopic extractor

#### Features

- Ducted/re-circulating installation
- 3 speeds
- Rocker switch
- Aluminium grease filter
- 2 x 3W LED lights

#### Optional accessories

- Ducting kit, AED510/560
- Charcoal filter for re-circulation, CHA34 (pack of 2)

Available in stainless steel

Energy efficiency rating: D

#### Technical specification

Required height over gas hob: **750mm (min)**  
 Required height over electric hob: **650mm (min)**  
 Outlet diameter: **120mm**  
 Noise level: **59dBA**  
 Extraction rate: **260m<sup>3</sup>/h**  
 Rated electrical power: **131W**  
 Power supply required: **3A**

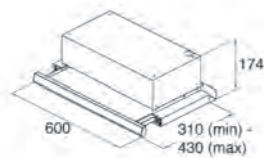

Open



Closed

### CTE9

Telescopic extractor

#### Features

- Ducted/re-circulating installation
- 3 speeds
- Rocker switch
- Aluminium grease filter
- 2 x 3W LED lights

#### Optional accessories

- Ducting kit, AED510/560
- Charcoal filter for re-circulation, CHA35 (pack of 2)

Available in stainless steel

Energy efficiency rating: D

#### Technical specification

Required height over gas hob: **750mm (min)**  
 Required height over electric hob: **650mm (min)**  
 Outlet diameter: **120mm**  
 Noise level: **63dBA**  
 Extraction rate: **367m<sup>3</sup>/h**  
 Rated electrical power: **226W**  
 Power supply required: **3A**

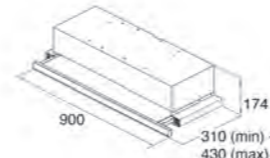

## Chimney extractors



### ECH61/71/91/101

Chimney extractor

**ECH61:** 60cm wide/ **ECH71:** 70cm wide/  
**ECH91:** 90cm wide/ **ECH101:** 100cm wide

#### Features

- Ducted/re-circulating installation
- 3 speeds
- Push button control
- Aluminium grease filters
- 2 x 3W LED lights
- Twin fan motor

#### Optional accessories

- Ducting kit, AED610/660
- Charcoal filter for re-circulation, CHA24 (pack of 2)

Available in stainless steel, black

Energy efficiency rating: D

#### Technical specification

Required height over gas hob: **700mm (min)**  
 Required height over electric hob: **600mm (min)**  
 Outlet diameter: **150mm**  
 Noise level: **64dBA**  
 Extraction rate: **427m<sup>3</sup>/h**  
 Rated electrical power: **146W**  
 Power supply required: **3A**

#### Fitting Notes

Please ensure that you check the ceiling height is sufficient to allow the required clearance between the hob and extractor.

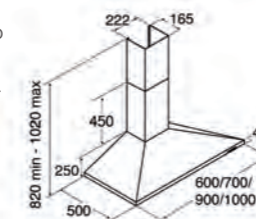

### ECP62/72/82/92/102/112

Curved glass extractor

**ECP62:** 60cm wide/ **ECP72:** 70cm wide/  
**ECP82:** 80cm wide/ **ECP92:** 90cm wide/ **ECP102:** 100cm wide/  
**ECP112:** 110cm wide/

#### Features

- Ducted/re-circulating installation
- 3 speeds
- Push button control
- Aluminium grease filters
- 2 x 2W LED lights

#### Optional accessories

- Ducting kits:
- 120mm, AED510/560
- 150mm, AED610/660
- Charcoal filter for re-circulation, CHA12 (pack of 1)

Available in stainless steel, black (excluding the ECP112)

Energy efficiency rating: D

#### Technical specification

Required height over gas hob: **700mm (min)**  
 Required height over electric hob: **600mm (min)**  
 Outlet diameter: **120mm/150mm**  
 Noise level: **60dBA**  
 Extraction rate: **ECP62/72/82 - 391m<sup>3</sup>/h, ECP92/102/112 - 377m<sup>3</sup>/h**  
 Rated electrical power: **104W**  
 Power supply required: **3A**

#### Fitting Notes

Please ensure that you check the ceiling height is sufficient to allow the required clearance between the hob and extractor.

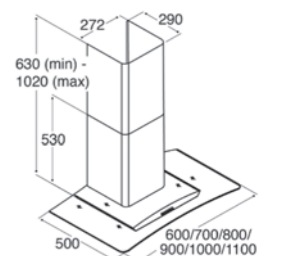

## Chimney extractors



### ECPK90

Curved glass island extractor

#### Features

- Ducted/re-circulating installation
- 3 speeds
- Push button control
- Aluminium grease filters
- 4 x 2W LED lights

#### Optional accessories

- Ducting kits:
  - 120mm, AED510/560
  - 150mm, AED610/660
- Charcoal filter for re-circulation, CHA25 (pack of 2)

Available in stainless steel

Energy efficiency rating: D

#### Technical specification

Required height over gas hob: **700mm (min)**  
 Required height over electric hob: **600mm (min)**  
 Outlet diameter: **120mm/150mm**  
 Noise level: **61dBA**  
 Extraction rate: **387m<sup>3</sup>/h**  
 Rated electrical power: **108W**  
 Power supply required: **3A**

#### Fitting Notes

Please ensure that you check the ceiling height is sufficient to allow the required clearance between the hob and extractor.

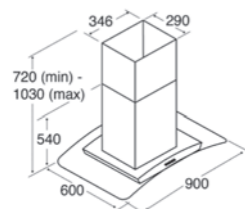

Stainless steel



Black

### EKP60/70/90

Curved glass extractor with edge lighting

**EKP60:** 60cm wide/ **EKP70:** 70cm wide/  
**EKP90:** 90cm wide

#### Features

- Ducted/re-circulating installation
- 3 speeds
- Touch control
- Aluminium grease filters
- 2 x 2W LED lights
- 3W of edge lighting
- 9 minute timer

#### Optional accessories

- Ducting kit, AED510/560
- Charcoal filter for re-circulation, CHA17 (pack of 2)

Available in stainless steel, black

Energy efficiency rating: D

#### Technical specification

Required height over gas hob: **700mm (min)**  
 Required height over electric hob: **600mm (min)**  
 Outlet diameter: **120mm**  
 Noise level: **69dBA**  
 Extraction rate: **336m<sup>3</sup>/h**  
 Rated electrical power: **127W**  
 Power supply required: **3A**

#### Fitting Notes

Please ensure that you check the ceiling height is sufficient to allow the required clearance between the hob and extractor.

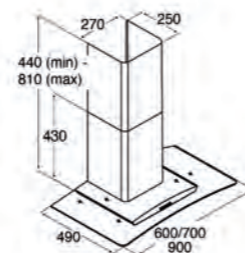

Stainless steel



Black

### EKPK90

Curved glass island extractor with edge lighting

#### Features

- Ducted/re-circulating installation
- 3 speeds
- Touch control
- Aluminium grease filters
- 4 x 2W LED lights
- 3W of edge lighting
- Timer function

#### Optional accessories

- Ducting kits:
  - 120mm, AED510/560
  - 150mm, AED610/660
- Charcoal filter for re-circulation, CHA12 (pack of 1)

Available in stainless steel, black

Energy efficiency rating: D

#### Technical specification

Required height over gas hob: **700mm (min)**  
 Required height over electric hob: **600mm (min)**  
 Outlet diameter: **120mm/150mm**  
 Noise level: **61dBA**  
 Extraction rate: **387m<sup>3</sup>/h**  
 Rated electrical power: **111W**  
 Power supply required: **3A**

#### Fitting Notes

Please ensure that you check the ceiling height is sufficient to allow the required clearance between the hob and extractor.

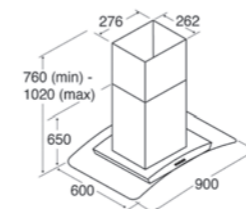

Stainless steel



Black

### ECN62/72/92

Flat glass extractor

**ECN60:** 60cm wide/ **ECN70:** 70cm wide/  
**ECN90:** 90cm wide

#### Features

- Ducted/re-circulating installation
- 3 speeds
- Push button control
- Aluminium grease filter
- 2 x 2W LED lights

#### Optional accessories

- Ducting kits:
  - 120mm, AED510/560
  - 150mm, AED610/660
- Charcoal filter for re-circulation, CHA12 (pack of 1)

Available in stainless steel, black

Energy efficiency rating: D

#### Technical specification

Required height over gas hob: **700mm (min)**  
 Required height over electric hob: **600mm (min)**  
 Outlet diameter: **120mm/150mm**  
 Noise level: **60dBA**  
 Extraction rate: **391m<sup>3</sup>/h**  
 Rated electrical power: **104W**  
 Power supply required: **3A**

#### Fitting Notes

Please ensure that you check the ceiling height is sufficient to allow the required clearance between the hob and extractor.

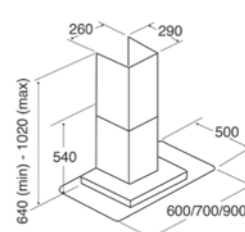



## ECNK90

Flat glass island extractor

### Features

- Ducted/re-circulating installation
- 3 speeds
- Push button control
- Aluminium grease filter
- 2 x 2W LED lights

### Optional accessories

- Ducting kit, AED610/660
- Charcoal filter for re-circulation, CHA12 (pack of 1)

Available in stainless steel

Energy efficiency rating: A++

### Technical specification

Required height over gas hob: **700mm (min)**  
 Required height over electric hob: **600mm (min)**  
 Outlet diameter: **150mm**  
 Noise level: **61dBA**  
 Extraction rate: **627m<sup>3</sup>/h**  
 Rated electrical power: **74W**  
 Power supply required: **3A**

### Fitting Notes

Please ensure that you check the ceiling height is sufficient to allow the required clearance between the hob and extractor.

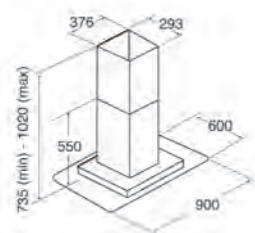

Stainless steel



Black

## EKN60/70/90

Flat glass extractor with edge lighting

**EKN60:** 60cm wide/ **EKN70:** 70cm wide/  
**EKN90:** 90cm wide

### Features

- Ducted/re-circulating installation
- 3 speeds
- Touch control
- Aluminium grease filter
- 2 x 2W LED lights
- 3W of edge lighting
- Timer function

### Optional accessories

- Ducting kits:
  - 120mm, AED510/560
  - 150mm, AED610/660
- Charcoal filter for re-circulation, CHA17 (pack of 2)

Available in stainless steel, black (excluding the EKN90)

Energy efficiency rating: D

### Technical specification

Required height over gas hob: **700mm (min)**  
 Required height over electric hob: **600mm (min)**  
 Outlet diameter: **120mm/150mm**  
 Noise level: **69dBA**  
 Extraction rate: **336m<sup>3</sup>/h**  
 Rated electrical power: **127W**  
 Power supply required: **3A**

### Fitting Notes

Please ensure that you check the ceiling height is sufficient to allow the required clearance between the hob and extractor.

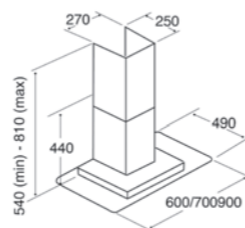

EVP61



EVP91

## EVP61/91/101/121

Linear extractor

**EVP61:** 60cm wide/**EVP91:** 90cm wide/  
**EVP101:** 100cm wide/**EVP121:** 120cm wide

### Features

- Ducted/re-circulating installation
- 3 speeds + intensive
- Touch control
- Aluminium grease filters
- 2 x 2W LED lights
- Twin fan motor
- Filter saturation warning light
- Clean air function
- 15 minute timer

### Optional accessories

- Ducting kit, AED610/660
- Charcoal filter for re-circulation, CHA21 (pack of 2)

Available in stainless steel

Energy efficiency rating: C

### Technical specification

Required height over gas hob: **700mm (min)**  
 Required height over electric hob: **600mm (min)**  
 Outlet diameter: **150mm**  
 Noise level: **62dBA**  
 Extraction rate: **503m<sup>3</sup>/h**  
 Rated electrical power: **252W**  
 Power supply required: **3A**

### Fitting Notes

Please ensure that you check the ceiling height is sufficient to allow the required clearance between the hob and extractor.

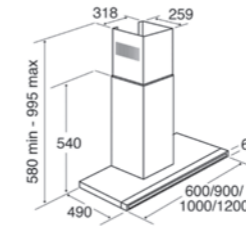

## EVPK90

Linear island extractor

### Features

- Ducted/re-circulating installation
- 3 speeds + intensive
- Touch control
- Aluminium grease filters
- 4 x 4W LED lights
- Twin fan motor
- Filter saturation warning light
- Clean air function
- 15 minute timer

### Optional accessories

- Ducting kit, AED610/660
- Charcoal filter for re-circulation, CHA21 (pack of 2)

Available in stainless steel

Energy efficiency rating: C

### Technical specification

Required height over gas hob: **700mm (min)**  
 Required height over electric hob: **600mm (min)**  
 Outlet diameter: **150mm**  
 Noise level: **64dBA**  
 Extraction rate: **520m<sup>3</sup>/h**  
 Rated electrical power: **254W**  
 Power supply required: **3A**

### Fitting Notes

Please ensure that you check the ceiling height is sufficient to allow the required clearance between the hob and extractor.

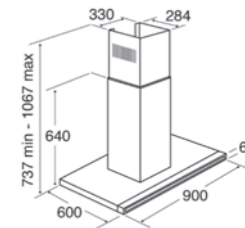

## Angled extractors



EVA60



EVA90

### EVA60/70/90

Angled extractor

**EVA60:** 60cm wide/**EVA70:** 70cm wide/  
**EVA90:** 90cm wide

#### Features

- Ducted/re-circulating installation
- 3 speeds
- Touch control
- Aluminium grease filter
- 2 x 2W LED lights
- Twin fan motor
- 15 minute timer

#### Optional accessories

- Ducting kit, AED510/560
- Charcoal filter for re-circulation, CHA15 (pack of 1)

Available in black

Energy efficiency rating: B

#### Technical specification

Required height over gas hob: **550mm (min)**  
Required height over electric hob: **550mm (min)**  
Outlet diameter: **120mm**  
Noise level: **64dBA**  
Extraction rate: **350m<sup>3</sup>/h**  
Rated electrical power: **114W**  
Power supply required: **3A**

#### Fitting Notes

Please ensure that you check the ceiling height is sufficient to allow the required clearance between the hob and extractor.

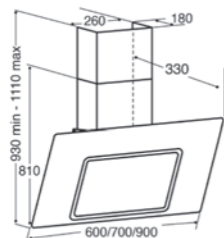

Black

### EVG6

Angled glass extractor

#### Features

- Ducted/re-circulating installation
- 3 speeds + intensive
- Touch control
- Aluminium grease filter
- 2 x 2W LED lights
- Twin fan motor
- Filter saturation warning light
- Clean air function
- 15 minute timer

#### Optional accessories

- Ducting kit, AED610/660
- Charcoal filter for re-circulation, CHA21 (pack of 2)

Available in black

Energy efficiency rating: C

#### Technical specification

Required height over gas hob: **CDA hob - 450mm (min), Other hobs - 760mm (min)**  
Required height over electric hob: **CDA hob - 450mm (min), Other hobs - 650mm (min)**  
Outlet diameter: **150mm**  
Noise level: **58dBA**  
Extraction rate: **422m<sup>3</sup>/h**  
Rated electrical power: **252W**  
Power supply required: **3A**

#### Fitting Notes

Please ensure that you check the ceiling height is sufficient to allow the required clearance between the hob and extractor.

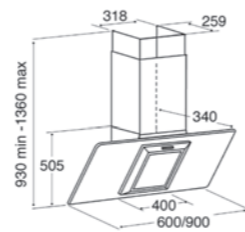

## Gesture control



EXG90



EXG60

### EXG60/90

Gesture control angled extractor

**EXG60:** 60cm wide/**EXG90:** 90cm wide

#### Features

- Ducted/re-circulating installation
- 3 speeds + intensive
- Gesture control
- Touch control
- Aluminium grease filter
- 1 x 8W LED strip light
- 15 minute timer

#### Optional accessories

- Ducting kit, AED610/660
- Charcoal filter for re-circulation, CHA37 (pack of 2)

Available in black

Energy efficiency rating: A

#### Technical specification

Required height over gas hob: **650mm (min)**  
Required height over electric hob: **CDA hob - 450mm (min), Other hobs - 650mm (min)**  
Outlet diameter: **150mm**  
Noise level: **68dBA**  
Extraction rate: **EXG60 - 619m<sup>3</sup>/h, EXG90 - 611m<sup>3</sup>/h**  
Rated electrical power: **308W**  
Power supply required: **3A**

#### Fitting Notes

Please ensure that you check the ceiling height is sufficient to allow the required clearance between the hob and extractor.

## Statement



### EVQ71

Circular extractor

#### Features

- Ducted/re-circulating installation
- 3 speeds
- Touch control
- Aluminium grease filter
- 2 x 2W LED lights
- Timer function

#### Optional accessories

- Ducting kit, AED610/660
- Charcoal filter for re-circulation, CHA33 (pack of 2)

Available in stainless steel with black glass fascia

Energy efficiency rating: A++

#### Technical specification

Required height over gas hob: **700mm (min)**  
Required height over electric hob: **600mm (min)**  
Outlet diameter: **150mm**  
Noise level: **62dBA**  
Extraction rate: **579m<sup>3</sup>/h**  
Rated electrical power: **74W**  
Power supply required: **3A**

#### Fitting Notes

Please ensure that you check the ceiling height is sufficient to allow the required clearance between the hob and extractor.

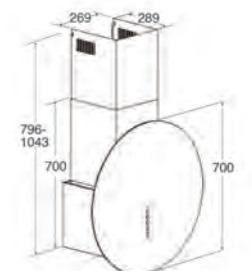

## Linear extractors



### EVX90

Ceiling extractor

#### Features

- Ducted/re-circulating installation
- 3 speeds
- Remote control
- Aluminium grease filter
- 4 x 4W LED lights
- 15 minute timer
- External motor included

#### Accessories

- Remote control

#### Optional accessories

- Ducting kit, AED610/660
- Charcoal filter for re-circulation, CHA12 (pack of 1)

Available in stainless steel

Energy efficiency rating: B

#### Technical specification

Required height over gas hob: **750mm (min)**  
 Required height over electric hob: **750mm (min)**  
 Outlet diameter: **150mm**  
 Noise level: **69dBA**  
 Extraction rate: **650m<sup>3</sup>/h**  
 Rated electrical power: **178W**  
 Power supply required: **3A**

#### Fitting Notes

The extraction outlet can be rotated through 90°, 180° or 270°, allowing for flexible installation.

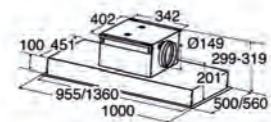

### EVS90

Ceiling extractor

#### Features

- Ducted installation
- 2 speeds + 2 intensive
- Remote control
- Aluminium grease filters
- 20 x 0.95W Micro LED lights
- Timer function
- Peripheral aspiration
- External motor included

#### Accessories

- Remote control

#### Optional accessories

- Ducting kit, AED610/660

Available in black

Energy efficiency rating: C

#### Technical specification

Required height over gas hob: **650mm (min)**  
 Required height over electric hob: **650mm (min)**  
 Outlet diameter: **150mm**  
 Noise level: **61dBA**  
 Extraction rate: **706m<sup>3</sup>/h**  
 Rated electrical power: **355W**  
 Power supply required: **3A**

#### Fitting Notes

Please ensure that you check the ceiling height is sufficient to allow the required clearance between the hob and extractor.

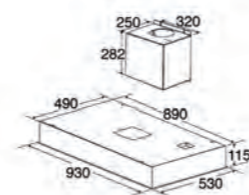

## Statement extractor



### EDD62/92

Downdraft extractor

EDD62: 60cm wide/ EDD92: 90cm wide

#### Features

- Ducted/re-circulating installation
- 3 speeds
- Touch control
- Aluminium grease filters
- 15 minute timer
- Synchronised sliding system
- Glass control panel
- Motor included

#### Optional accessories

- Ducting kit, AED610/660
- Charcoal filter for re-circulation, CHA12 (pack of 1)

Available in black

Energy efficiency rating: A

#### Technical specification

Outlet diameter: **150mm**  
 Noise level: **EDD62- 67dBA, EDD92 - 69dBA**  
 Extraction rate: **EDD62 - 566m<sup>3</sup>/h, EDD92 - 520m<sup>3</sup>/h**  
 Rated electrical power: **186W**

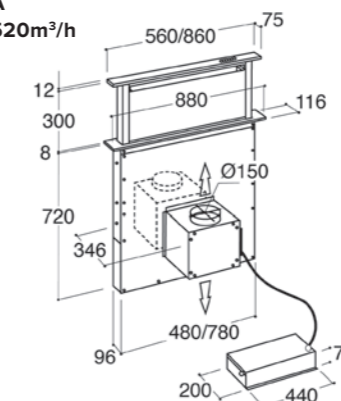



## Refrigeration

Our refrigeration range includes all you need to keep your food fresh and tasty. With fantastic features across the range, CDA have options to suit your kitchen.

### Under-counter cooling

Under-counter cooling is an ideal solution if you struggle for space or need extra storage. Our under-counter fridges and freezers will fit comfortably beneath your worktop without compromising on style and functionality. The **FW254** is full of handy features to help you store your weekly shop, including an ice box, salad crisper and in-door balconies.

### LED interior lighting

LED interior lighting makes it easy to find what you're looking for, emits no heat and runs on very little energy.

### Frost-free technology

Some appliances in our cooling range include useful frost-free technology that prevents the build-up of ice in the freezer compartment. This means that you will never have to defrost your freezer again!

### Complete cooling system

For the ultimate cooling station, combine our **FF821** fridge and **FF881** freezer with our full height **FWC881** wine cooler. Fitting together perfectly, these appliances create a high-capacity cooling centre for all types of fresh food and wine.

The **FWC881** wine cooler is capable of holding a staggering 117 bottles of wine, whilst the **FF821** and **FF881** combined boast an impressive 670L capacity and offer endless storage possibilities. This station is a great focal point in the kitchen and will complement any modern cooking space.



# Quick guide to integrated refrigeration

Integrated models offer a variety of fridge, freezer and combination options to suit your kitchen.

All CDA fridges have an automatic self-defrosting feature so you never have to spend time defrosting your fridge.

## Integrated refrigeration



- FW224**
- Integrated/under counter larder fridge
  - Interior light
  - 3 glass shelves
  - [Details on p82](#)



- FW254**
- Integrated/under counter fridge with ice box
  - Interior light
  - 2 glass shelves
  - [Details on p82](#)



- FW284**
- Integrated/under counter freezer
  - 4 star rating
  - 3 storage compartments
  - [Details on p83](#)



- FW321**
- Integrated/under counter larder fridge
  - Interior light
  - 3 stainless steel edged glass shelves
  - [Details on p83](#)



- FW381**
- Integrated/under counter freezer
  - 4 star rating
  - 3 storage compartments
  - [Details on p84](#)



- FW422**
- Integrated in-column larder fridge
  - Interior light
  - 4 glass shelves
  - [Details on p84](#)



- FW482**
- Integrated in-column freezer
  - 4 star rating
  - 4 storage compartments
  - [Details on p85](#)



- FW522**
- Integrated three-quarter height larder fridge
  - LED interior light
  - 4 glass shelves
  - [Details on p85](#)



- FW582**
- Integrated three-quarter height freezer
  - 4 star rating
  - 5 storage compartments
  - [Details on p86](#)



- FW821**
- Integrated full height larder fridge
  - LED interior lighting
  - 6 glass shelves
  - [Details on p86](#)



- FW881**
- Integrated full height freezer
  - 4 star rating
  - Temperature warning light
  - [Details on p87](#)



- FW822**
- Integrated full height larder fridge
  - LED interior lighting
  - Electronic temperature control
  - [Details on p87](#)



- FW882**
- Integrated full height freezer
  - 4 star rating
  - Electronic temperature control
  - [Details on p88](#)



- FW852**
- Integrated 50/50 combination fridge freezer
  - LED interior lighting
  - Electronic control
  - [Details on p88](#)



- FW872**
- Integrated 70/30 combination fridge freezer
  - LED interior lighting
  - Electronic control
  - [Details on p89](#)



- FW925**
- Integrated 50/50 combination frost free fridge freezer
  - LED interior lighting
  - Electronic control
  - [Details on p89](#)



- FW927**
- Integrated 70/30 combination frost free fridge freezer
  - LED interior lighting
  - Electronic control
  - [Details on p90](#)



- FW952**
- Integrated 50/50 frost free fridge freezer
  - Eco Mode
  - Holiday Mode
  - [Details on p90](#)



- FW972**
- Integrated 70/30 frost free fridge freezer
  - Eco Mode
  - Holiday Mode
  - [Details on p91](#)

## Wine coolers

Please see our wine cooler section for our wide range of chilled beverage appliances.

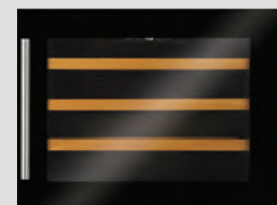

- FWV452**
- Built-in compact wine cooler
  - [Details on p100](#)

# Quick guide to freestanding refrigeration

## Freestanding refrigeration



### FF881

- Freestanding full height frost free freezer
  - Electronic control with LED display
  - Temperature rise signal
- [Details on p92](#)



### FF821

- Freestanding full height larder fridge
  - Electronic control with LED display
  - Temperature rise signal
- [Details on p92](#)

## Integrated refrigeration



### FW224

Integrated/under counter larder fridge

#### Features

- Interior light
- 3 glass shelves
- 2 salad crisper compartments
- 2 in-door balconies
- 1 egg tray
- Height adjustable feet
- Reversible door
- Fixed hinges

#### Energy consumption

Energy consumption per annum: **116kW.h**

#### Energy efficiency rating

- Energy rating: F

#### Technical specification

Total usable capacity: **135L net**

Noise level: **40dBA**

Noise Emission Class: **C**

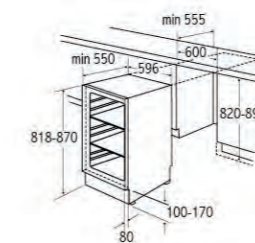

### FW254

Integrated/under counter fridge with ice box

#### Features

- Interior light
- 2 glass shelves
- 2 salad crisper compartments
- 2 in-door balconies
- 1 egg tray
- Height adjustable feet
- Reversible door
- Fixed hinges

#### Fridge features

- Fridge usable capacity: **95L net**

#### Ice box features

- Ice box usable capacity: **16L net**
- 4 star rating
- 1 ice cube tray

#### Energy consumption

Energy consumption per annum: **183kW.h**

#### Energy efficiency rating

- Energy rating: F

#### Technical specification

Total usable capacity: **111L net**

Noise level: **39dBA**

Noise Emission Class: **C**

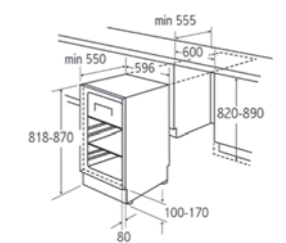

## Product-specific features

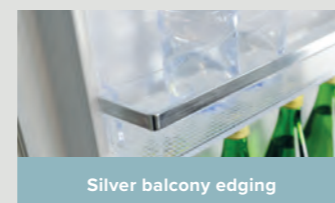
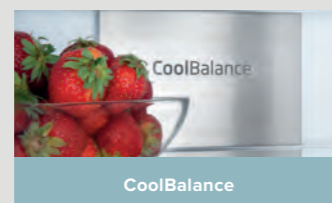



## FW284

Integrated/under counter freezer

### Features

- 4 star rating
- 3 storage compartments
- 1 ice cube tray
- Height adjustable feet
- Reversible door
- Fixed hinges

### Freezer features

- Freezer usable capacity:
- Freezing capacity: **Freezing capacity: 11kg/24h**

### Energy consumption

Energy consumption per annum: **220kW.h**

### Energy efficiency rating

- Energy rating: F

### Technical specification

Total usable capacity: **95L net**  
 Noise level: **40dBA**  
 Noise Emission Class: **C**

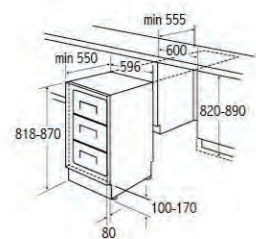

## FW321

Integrated/under counter larder fridge

### Features

- Interior light
- 3 stainless steel edged glass shelves
- 1 salad crisper compartment
- 2 in-door balconies
- 1 egg tray
- Height adjustable feet
- Reversible door
- Fixed hinges

### Energy consumption

Energy consumption per annum: **116kW.h**

### Energy efficiency rating

- Energy rating: F

### Technical specification

Total usable capacity: **134L net**  
 Noise level: **39dBA**  
 Noise Emission Class: **C**

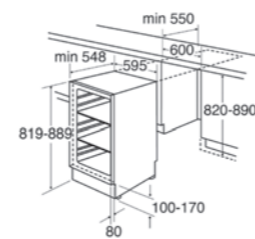

## FW381

Integrated/under counter freezer

### Features

- 4 star rating
- 3 storage compartments
- 1 ice cube tray
- Height adjustable feet
- Reversible door
- Fixed hinges

### Freezer features

- Freezing capacity: **9kg/24h**

### Energy consumption

Energy consumption per annum: **220kW.h**

### Energy efficiency rating

- Energy rating: F

### Technical specification

Total usable capacity: **96L net**  
 Noise level: **39dBA**  
 Noise Emission Class: **C**

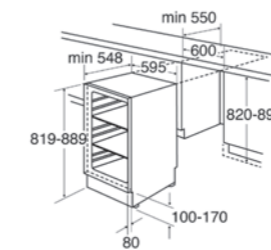

## FW422

Integrated in-column larder fridge

### Features

- Interior light
- 4 glass shelves
- 2 salad crisper drawers
- 3 in-door balconies
- 1 egg tray
- Reversible door
- Fixed hinges

### Energy consumption

Energy consumption per annum: **116kW.h**

### Energy efficiency rating

- Energy rating: F

### Technical specification

Total usable capacity: **134L net**  
 Noise level: **38dBA**  
 Noise Emission Class: **C**

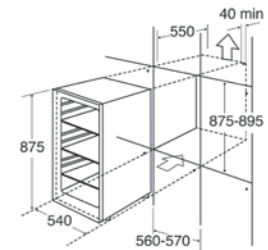



## FW482

Integrated in-column freezer

### Features

- 4 star rating
- 4 storage compartments
- 1 ice cube tray
- Reversible door
- Fixed hinges

### Freezer features

- Freezing capacity: **8kg/24h**

### Energy consumption

Energy consumption per annum: **221kW.h**

### Energy efficiency rating

- Energy rating: F

### Technical specification

Total usable capacity: **95L net**  
 Noise level: **38dBA**  
 Noise Emission Class: **C**

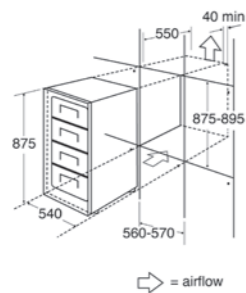

## FW522

Integrated three-quarter height larder fridge

### Features

- LED interior light
- 4 glass shelves
- 1 salad crisper drawer
- 3 in-door balconies
- 1 egg tray
- Height adjustable feet
- Reversible door
- Fixed hinges

### Energy consumption

Energy consumption per annum: **125kW.h**

### Energy efficiency rating

- Energy rating: F

### Technical specification

Total usable capacity: **197L net**  
 Noise level: **39dBA**  
 Noise Emission Class: **C**

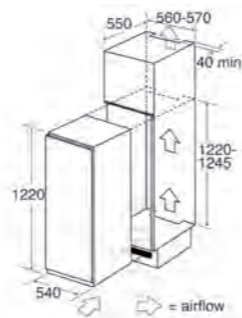

## FW582

Integrated three-quarter height freezer

### Features

- 4 star rating
- 5 storage compartments
- 1 ice cube tray
- Fast freeze
- Temperature warning light
- Height adjustable feet
- Reversible door
- Fixed hinges

### Freezer features

- Freezing capacity: **6.5kg/24h**

### Energy consumption

Energy consumption per annum: **233kW.h**

### Energy efficiency rating

- Energy rating: F

### Technical specification

Total usable capacity: **127L net**  
 Noise level: **40dBA**  
 Noise Emission Class: **C**

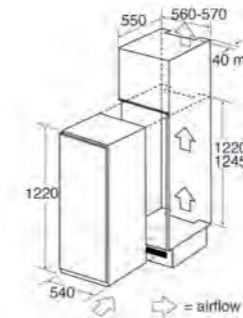

## FW821

Integrated full height larder fridge

### Features

- LED interior lighting
- 6 glass shelves
- 2 salad crisper drawers
- 5 in-door balconies
- 1 egg tray
- Front adjustable feet
- Reversible door
- Sliding furniture fixings

### Energy consumption

Energy consumption per annum: **143kW.h**

### Energy efficiency rating

- Energy rating: F

### Technical specification

Total usable capacity: **316L net**  
 Noise level: **39dBA**  
 Noise Emission Class: **C**

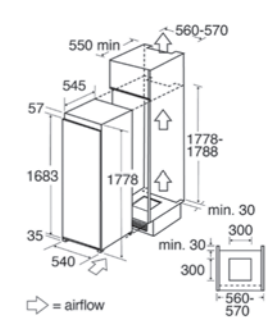



## FW881

Integrated full height freezer

### Features

- 4 star rating
- Temperature warning light
- Fast freeze
- 7 storage compartments
- 1 ice cube tray
- Front adjustable feet
- Reversible door
- Sliding furniture fixings

### Freezer features

- Freezing capacity: **10.5kg/24h**

### Energy consumption

Energy consumption per annum: **264kW.h**

### Energy efficiency rating

- Energy rating: F

### Technical specification

Total usable capacity: **204L net**  
 Noise level: **39dBA**  
 Noise Emission Class: **C**

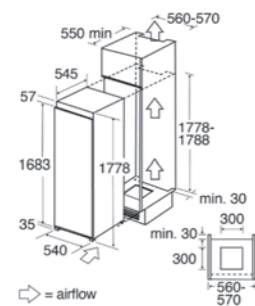

## FW822

Integrated full height larder fridge

### Features

- LED interior lighting
- Electronic temperature control
- 6 glass shelves
- 2 salad crisper drawers
- Chrome bottle rack
- 5 in-door balconies
- 1 egg tray
- Front adjustable feet
- Reversible door
- Sliding furniture fixings

### Energy consumption

Energy consumption per annum: **143kW.h**

### Energy efficiency rating

- Energy rating: F

### Technical specification

Total usable capacity: **316L net**  
 Noise level: **39dBA**  
 Noise Emission Class: **C**

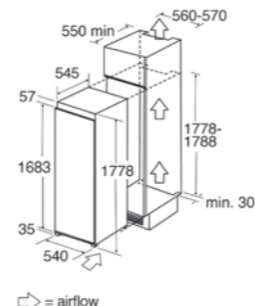

## FW882

Integrated full height freezer

### Features

- 4 star rating
- Electronic temperature control
- Frost free
- Fast freeze
- 7 storage compartments
- 1 ice cube tray
- Front adjustable feet
- Reversible door
- Sliding furniture fixings

### Freezer features

- Freezing capacity: **10.5kg/24h**

### Energy consumption

Energy consumption per annum: **289kW.h**

### Energy efficiency rating

- Energy rating: F

### Technical specification

Total usable capacity: **200L net**  
 Noise level: **41dBA**  
 Noise Emission Class: **C**

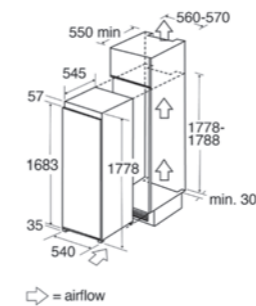

## FW852

Integrated 50/50 combination fridge freezer

### Features

- Reversible doors
- Sliding furniture fixings

### Fridge features

- Fridge usable capacity: **147L net**
- LED interior lighting
- Electronic control
- 3 glass shelves
- 2 salad crisper drawers
- 3 in-door balconies
- 1 egg tray
- Chrome bottle rack

### Freezer features

- Freezer usable capacity: **81L net**
- Freezing capacity: **4.5kg/24h**
- 4 star rating
- Fast freeze
- 4 storage compartments
- 1 ice cube tray

### Energy consumption

Energy consumption per annum: **272kW.h**

### Energy efficiency rating

- Energy rating: F

### Technical specification

Total usable capacity: **228L net**  
 Noise level: **39dBA**  
 Noise Emission Class: **C**

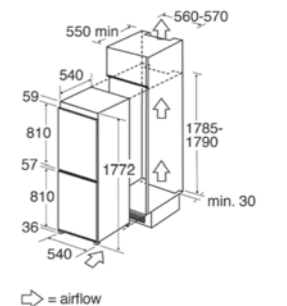



## FW872

Integrated 70/30 combination  
fridge freezer

### Features

- Reversible doors
- Sliding furniture fixings

### Fridge features

- Fridge usable capacity: **182L net**
- LED interior lighting
- Electronic control
- 4 glass shelves
- 2 salad crisper drawers
- 4 in-door balconies
- 1 egg tray
- Chrome bottle rack

### Freezer features

- Freezer usable capacity: **60L net**
- Freezing capacity: **3.5kg/24h**
- 4 star rating
- Fast freeze
- 3 storage compartments
- 1 ice cube tray

### Energy consumption

Energy consumption per annum: **256kW.h**

### Energy efficiency rating

- Energy rating: F

### Technical specification

Total usable capacity: **242L net**  
Noise level: **39dBA**  
Noise Emission Class: **C**

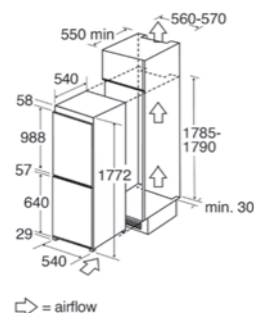

## FW925

Integrated 50/50 combination  
frost free fridge freezer

### Features

- Reversible doors
- Sliding furniture fixings

### Fridge features

- Fridge usable capacity: **158L net**
- LED interior lighting
- Electronic control
- 4 glass shelves
- 2 salad crisper drawers
- 3 in-door balconies
- 1 egg tray
- Chrome bottle rack

### Freezer features

- Freezer usable capacity: **77L net**
- Freezing capacity: **4.5kg/24h**
- 4 star rating
- Frost free
- 4 storage compartments
- 1 ice cube tray

### Energy consumption

Energy consumption per annum: **288kW.h**

### Energy efficiency rating

- Energy rating: F

### Technical specification

Total usable capacity: **235L net**  
Noise level: **41dBA**  
Noise Emission Class: **C**

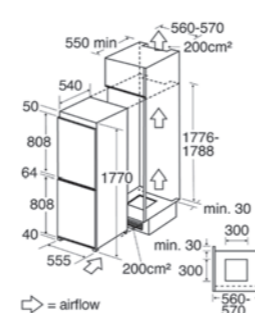

## FW927

Integrated 70/30 combination  
frost free fridge freezer

### Features

- Reversible doors
- Sliding furniture fixings

### Fridge features

- Fridge usable capacity: **190L net**
- LED interior lighting
- Electronic control
- 5 glass shelves
- 1 salad crisper drawer
- 3 in-door balconies
- 1 egg tray
- Chrome bottle rack

### Freezer features

- Freezer usable capacity: **56L net**
- Freezing capacity: **3.0kg/24h**
- 4 star rating
- Frost free
- 3 storage compartments
- 1 ice cube tray

### Energy consumption

Energy consumption per annum: **260kW.h**

### Energy efficiency rating

- Energy rating: F

### Technical specification

Total usable capacity: **246L net**  
Noise level: **41dBA**  
Noise Emission Class: **C**

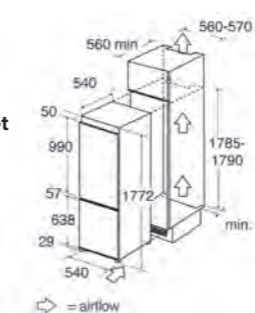

## FW952

Integrated 50/50  
frost free fridge freezer

### Features

- Eco Mode
- Holiday Mode
- Reversible doors
- Open door alert
- Fixed hinges

### Fridge features

- Fridge usable capacity: **153L net**
- LED interior lighting
- Electronic control
- 3 glass shelves
- 1 salad crisper drawers
- 3 in-door balconies
- 1 egg tray
- Foldable wine rack
- Super cool function
- CoolBalance

### Freezer features

- Freezer usable capacity: **89L net**
- 4 star rating
- Frost free
- 4 storage compartments
- 1 ice cube tray
- Super freeze function

### Energy consumption

Energy consumption per annum: **294kW.h**

### Energy efficiency rating

- Energy rating: F

### Technical specification

Noise level: **41dBA**  
Noise Emission Class: **C**

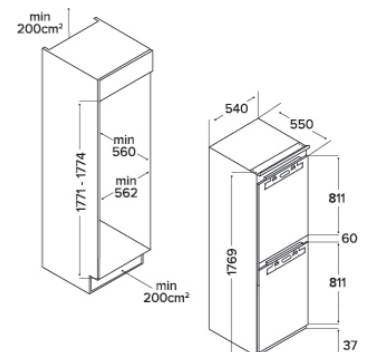

## Integrated refrigeration



### FW972

Integrated 70/30 frost free fridge freezer

#### Features

- Eco Mode
- Holiday Mode
- Reversible doors
- Open door alert
- Fixed hinges

#### Fridge features

- Fridge usable capacity: **177L net**
- LED interior lighting
- Electronic control
- 3 glass shelves
- 1 AdaptZone drawer
- 1 crisper drawer on metal sliders
- 3 in-door balconies
- 1 egg tray
- Foldable wine rack
- Super cool function
- CoolBalance

#### Freezer features

- Freezing capacity: **64L net**
- 4 star rating
- Frost free
- 3 storage compartments
- 1 ice cube tray
- Super freeze function

#### Energy consumption

Energy consumption per annum: **288kW.h**

#### Energy efficiency rating

- Energy rating: F

#### Technical specification

Noise level: **40dBA**  
Noise Emission Class: **C**

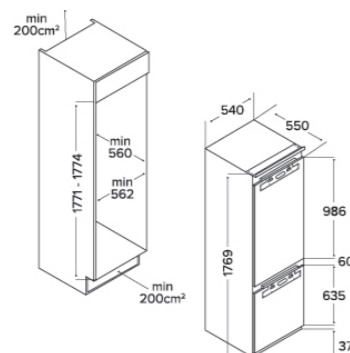

## Freestanding refrigeration



### FF881

Freestanding full height frost free freezer

#### Features

- Electronic control with LED display
- Temperature rise signal
- LED interior lighting
- 4 star rating
- Fast freeze
- 7 storage compartments
- Ice cube tray
- Frost free
- Front adjustable feet
- Reversible door

#### Freezer features

- Freezing capacity: **21kg/24h**

Available in stainless steel effect

#### Energy consumption

Energy consumption per annum: **311kW.h**

#### Energy efficiency rating

- Energy rating: F

#### Technical specification

Total usable capacity: **280L net**  
Noise level: **41dBA**  
Noise Emission Class: **C**

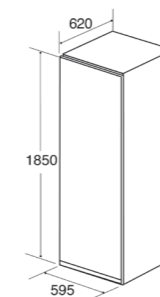

### FF821

Freestanding full height larder fridge

#### Features

- Electronic control with LED display
- Temperature rise signal
- LED interior lighting
- 5 adjustable glass shelves
- 2 salad crispers
- 5 in-door balconies
- Super cooling
- Front adjustable feet
- Reversible door

Available in stainless steel effect

#### Energy consumption

Energy consumption per annum: **152kW.h**

#### Energy efficiency rating

- Energy rating: F

#### Technical specification

Total usable capacity: **390L net**  
Noise level: **41dBA**  
Noise Emission Class: **C**

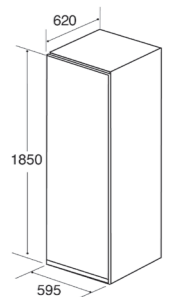

**5**  
YEARS  
PARTS  
2 YEARS LABOUR



## Wine coolers

Using anti-vibration technology, UV-protection and temperature control, CDA wine coolers keep your collection in optimum condition.

### UV-protective glass doors

All CDA wine coolers have UV-protective, toughened, smoked glass doors to prevent sunlight spoiling the wine. This also assists thermal efficiency.

### Luxury wooden shelving

Our wine coolers feature luxury solid wooden shelves as standard (excludes 15cm slimline models). The **FWV902** integrated model also has the addition of a luxury wooden display shelf.

### Wine cooler glass shelf

Our optional wine cooler glass shelf is perfect for storing smaller items such as bottles and cans - compatible with the **FWC304**, **FWC604**, **FWC624** and **FWC881** models. Please see our accessory section for details.

### Digital temperature control

All CDA wine coolers are designed with electronic temperature control, which is adjustable between 5°C and 20°C. The white digital display is easy to use and has a convenient memory function.

### LED lighting

Bright LED lighting illuminates the internal cavity beautifully and makes finding the right bottle quick and easy.



# Quick guide to wine coolers

All our wine coolers feature the characteristic sleek, minimalist design of the CDA range.

A wide variety of sizes are available, meaning there's one to suit every kitchen space.



## FWC153

- Freestanding/under counter slimline wine cooler

[Details on p97](#)



## FWC304

- Freestanding/under counter slimline wine cooler

[Details on p97](#)



## FWC604

- Freestanding/under counter wine cooler

[Details on p98](#)



## FWC624

- Freestanding/under counter double door wine cooler

[Details on p98](#)



## FWC881

- Full height freestanding wine cooler

[Details on p99](#)



## FWV902

- Integrated wine cooler

[Details on p99](#)

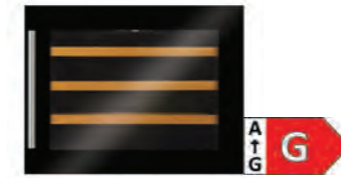

## FWV452

- Integrated compact wine cooler

[Details on p100](#)



## FWV601

- Integrated compact wine cooler

[Details on p100](#)

## Improved safety

Variations in temperature, light and movement can all accelerate the ageing process of wine and damage your collection. All of our wine coolers come with the latest technology to provide the perfect storage solution. As part of our continued commitment to safety, we have now introduced metal backing to our wine cooler range.

## Freestanding wine coolers

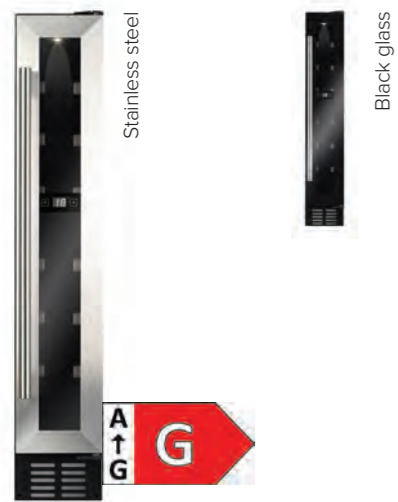

### FWC153

Freestanding/under counter slimline wine cooler

#### Features

- Stores 7 (75cL Bordeaux) bottles
- Black plinth
- White LED display
- Single temperature storage zone
- 6 integrated supports
- Electronic temperature control
- UV-protective toughened smoked glass door
- Triple glazed door
- LED interior lighting
- Temperature memory function
- Over temperature alarm
- Height adjustable plinth section
- Door open alarm
- Compressor driven

Available in stainless steel, black glass

#### Optional accessories

- Glass shelves (pack of 3), AFG61

#### Energy consumption

Energy consumption per annum: **145kW.h**

Energy efficiency rating: **G**

#### Technical specification

Reversible door  
Current of product: **0,4A**  
Noise level: **40dBA**  
Noise emission class: **C**  
Temperature range: **5°C to 20°C**

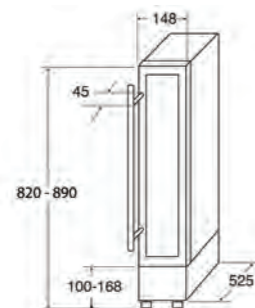

### FWC304

Freestanding/under counter slimline wine cooler

#### Features

- Stores 20 (75cL Bordeaux) bottles
- Black plinth
- White LED display
- Single temperature storage zone
- 5 wooden slide-out shelves
- Electronic temperature control
- UV-protective toughened smoked glass door
- Double glazed door
- LED interior lighting
- Temperature memory function
- Over temperature alarm
- Height adjustable plinth section
- Humidifier to maintain 50-80% RH
- Door open alarm
- Compressor driven

Available in stainless steel, black glass

#### Optional accessories

- Glass shelves (pack of 3), AFG61

#### Energy consumption

Energy consumption per annum: **150kW.h**

Energy efficiency rating: **G**

#### Technical specification

Reversible door  
Current of product: **0,6A**  
Noise level: **40dBA**  
Noise emission class: **C**  
Temperature range: **5°C to 20°C**

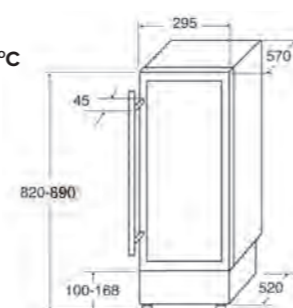

### FWC604

Freestanding/under counter wine cooler

#### Features

- Stores 45 (75cL Bordeaux) bottles
- Black plinth
- White LED display
- Dual temperature storage zones
- 5 wooden slide-out shelves
- Electronic temperature control
- UV-protective toughened smoked glass door
- Double glazed door
- LED interior lighting
- Temperature memory function
- Over temperature alarm
- Height adjustable plinth section
- Integral heater
- Humidifier to maintain 50-80% RH
- Door open alarm
- Compressor driven

Available in stainless steel, black glass

#### Optional accessories

- Glass shelves (pack of 3), AFG61

#### Energy consumption

Energy consumption per annum: **159kW.h**

Energy efficiency rating: **G**

#### Technical specification

Reversible door  
Current of product: **1,2A**  
Noise level: **40dBA**  
Noise emission class: **C**

#### Upper zone

Temperature range: **5°C to 20°C**  
Stores 15 (75cL Bordeaux) bottles

#### Lower zone

Temperature range: **5°C to 20°C**  
Stores 30 (75cL Bordeaux) bottles

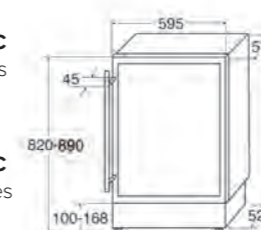

### FWC624

Freestanding/under counter double door wine cooler

#### Features

- Stores 40 (75cL Bordeaux) bottles
- Black plinth
- White LED display
- Dual temperature storage zones
- 11 wooden slide-out shelves
- Electronic temperature control
- UV-protective toughened smoked glass door
- Double glazed door
- LED interior lighting
- Temperature memory function
- Over temperature alarm
- Height adjustable plinth section
- Humidifier to maintain 50-80% RH
- Door open alarm
- Compressor driven

Available in stainless steel, black glass

#### Optional accessories

- Glass shelves (pack of 3), AFG61

#### Energy consumption

Energy consumption per annum: **158kW.h**

Energy efficiency rating: **G**

#### Technical specification

Current of product: **1,2A**  
Noise level: **42dBA**  
Noise emission class: **D**

#### Upper zone

Temperature range: **5°C to 20°C**  
Stores 20 (75cL Bordeaux) bottles

#### Lower zone

Temperature range: **5°C to 20°C**  
Stores 20 (75cL Bordeaux) bottles

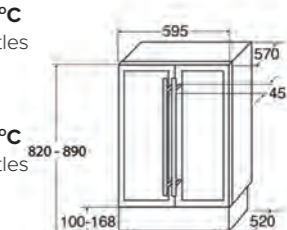

## Freestanding wine cooler

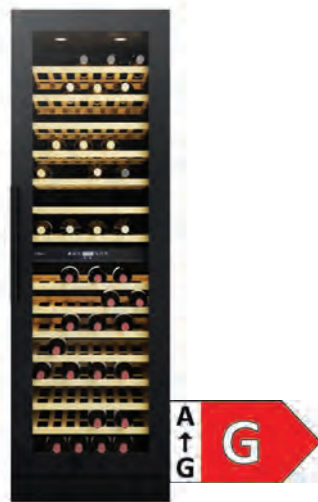

### FWC881

Full height freestanding wine cooler

#### Features

- Stores 117 (75cL Bordeaux) bottles
- Black plinth
- White LED display
- Dual temperature storage zones
- 14 wooden slide-out shelves
- Electronic temperature control
- UV-protective toughened smoked glass door
- Triple glazed door
- LED interior lighting
- Energy saving mode
- Temperature memory function
- Over temperature alarm
- Door open alarm
- Humidifier in upper zone to maintain 50-80% RH
- Integral heater
- Compressor driven

Available in Black

#### Optional accessories

- Glass shelves (pack of 3), AFG61

#### Energy consumption

Energy consumption per annum: **187kW.h**

Energy efficiency rating: **G**

#### Technical specification

Reversible door  
Height adjustable feet  
Current of product: **1,4A**  
Noise level: **41dBA**  
Noise emission class: **C**

#### Upper zone

Temperature range: **5°C to 20°C**  
Stores 55 (75cL Bordeaux) bottles

#### Lower zone

Temperature range: **5°C to 20°C**  
Stores 62 (75cL Bordeaux) bottles

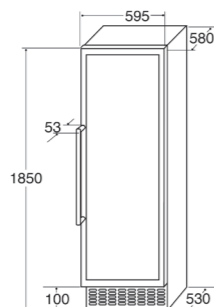

## Integrated wine coolers



### FWV902

Integrated wine cooler

#### Features

- Stores 57 (75cL Bordeaux) bottles or 52 when using display shelf
- White LED display
- Dual temperature storage zones
- 5 wooden slide-out shelves and 1 wooden display shelf
- Electronic temperature control
- UV-protective toughened smoked glass door
- Triple glazed door
- LED interior lighting
- Temperature memory function
- Over temperature alarm
- Door open alarm
- Energy saving mode
- Display light function
- Humidifier to maintain 50-80% RH
- 1 wooden display shelf
- Compressor driven

Available in Black

#### Optional accessories

- Glass shelves (pack of 3), AFG61

#### Energy consumption

Energy consumption per annum: **162kW.h**

Energy efficiency rating: **G**

#### Technical specification

Reversible door  
Current of product: **1,2A**  
Noise level: **40dBA**  
Noise emission class: **C**

#### Upper zone

Temperature range: **5°C to 20°C**  
Stores 22 (75cL Bordeaux) bottles

#### Lower zone

Temperature range: **5°C to 20°C**  
Stores 35 (75cL Bordeaux) bottles or 30 when using display shelf

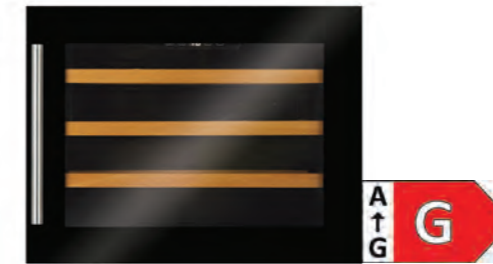
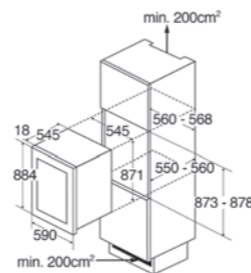

### FWV452

Integrated compact wine cooler

#### Features

- Stores 24 (75cL Bordeaux) bottles
- White LED display
- Single temperature storage zone
- 3 wooden slide-out shelves
- Electronic temperature control
- UV-protective toughened smoked glass door
- Triple glazed door
- LED interior lighting
- Temperature memory function
- Over temperature alarm
- Door open alarm
- Energy saving mode
- Display light function
- Humidifier to maintain 50-80% RH
- Compressor driven

Available in Black

#### Optional accessories

- Glass shelves (pack of 3), AFG61

#### Energy consumption

Energy consumption per annum: **153kW.h**

Energy efficiency rating: **G**

#### Technical specification

Reversible door  
Current of product: **0,6A**  
Noise level: **39dBA**  
Noise emission class: **C**  
Temperature range: **5°C to 20°C**

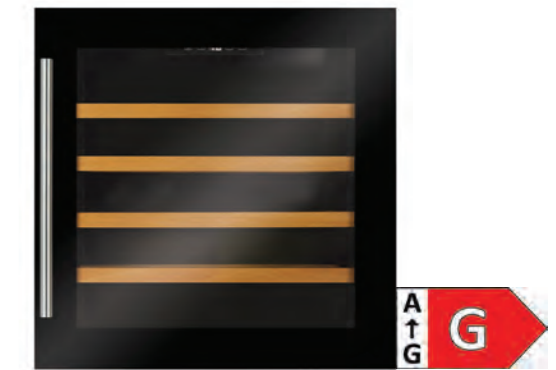
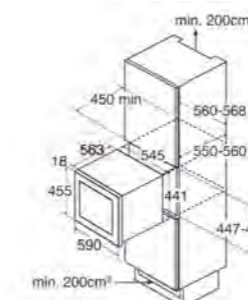

### FWV601

Integrated compact wine cooler

#### Features

- Stores 40 (75cL Bordeaux) bottles
- White LED display
- Single temperature storage zone
- 4 wooden slide-out shelves
- Electronic temperature control
- UV-protective toughened smoked glass door
- Triple glazed door
- LED interior lighting
- Temperature memory function
- Over temperature alarm
- Door open alarm
- Energy saving mode
- Display light function
- Humidifier to maintain 50-80% RH
- Compressor driven

Available in Black

#### Optional accessories

- Glass shelves (pack of 3), AFG61

#### Energy consumption

Energy consumption per annum: **157kW.h**

Energy efficiency rating: **G**

#### Technical specification

Reversible door  
Current of product: **1,2A**  
Noise level: **39dBA**  
Noise emission class: **C**  
Temperature range: **5°C to 20°C**

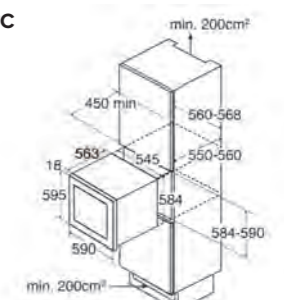

5

YEARS  
PARTS  
2 YEARS LABOUR



## Dishwashers

CDA dishwashers have been designed with function and performance in mind. Combining energy-saving features and intelligent technology, they deliver perfect results every time.

### Flood protection

All our dishwashers come complete with a leak detection function to help avoid flood damage in your home. For total peace of mind, the Aquastop system in models like the **CDI4251** dishwasher will automatically cut off the water supply in the event of a leak or flood being detected.

### Water consumption

It is a common misconception that dishwashers use more water than washing up by hand. The average household will complete two lots of washing up per day, using 21 litres of water each time. In comparison, CDA dishwashers use just 9 litres of water per load, and hold up to 15 place settings. This makes using a CDA dishwasher a far more efficient and environmentally friendly way to take care of the dishes.

### Top level cutlery drawer

The **CDI6371**, **CDI6241** and **CDI4251** features a useful top cutlery drawer with easy grip handles - simply pull the drawer out to retrieve your clean cutlery. Not only this, but the lower compartment in the **CDI6371** comes with folding racks and a height-adjustable upper basket to create more space for those larger pots and pans.

### Drying

Turbo drying on models like the **CDI6371**, **CDI6241** and **CDI4251** means that your dishwasher doesn't rely on passive heat to dry the dishes. Instead, it forces air around the cavity using a fan, drying them quickly and efficiently.

# Quick guide to dishwashers

CDA dishwashers combine state-of-the-art technology with meticulous build quality to give you reliable performance for years to come.

All our dishwashers feature:

- Cold water fill
- Counter-balanced door
- Upper height-adjustable basket to accommodate larger items
- Concealed heating element to protect the bottom basket
- Delay timer to take advantage of off-peak electricity
- LED info dot feature
- Elegant white LEDS
- Antibacterial filter

## Dishwashers



**CDI4121**  
 • 45cm Slimline Integrated Dishwasher  
 • 10 place settings  
 • 6 programmes  
 • Delay timer  
 Details on **p104**



**CDI4251**  
 • 45cm Slimline Integrated Dishwasher  
 • 10 place settings  
 • 7 programmes  
 • Turbo drying  
 Details on **p104**



**CDI4121**  
 45cm Slimline Integrated Dishwasher

### Features

- 10 place settings
- 6 programmes
- Delay timer
- LED Info Dot feature
- Half load
- White LED indicators
- Antibacterial filter
- Hygiene programme
- Adjustable feet
- Aquazone

### 6 programmes

- Eco
- Intensive
- Hygiene Pro
- Super
- Quick
- Prewash

### Energy consumption

Energy consumption per 100 cycles: **76kwh**  
 Eco programme water consumption: **9L**

### Energy efficiency rating

- Energy rating: **E**

### Technical specification

Rated electrical power: **1.9kW**  
 Power cord length: **165cm**  
 Noise Level: **47db**  
 Noise Class: **C**

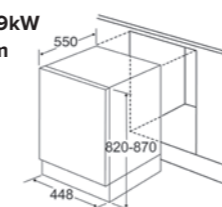

**CDI4251**  
 45cm Slimline Integrated Dishwasher

### Features

- 10 place settings
- 7 programmes
- 3 spray levels
- LED Info Dot feature
- Half load
- White LED indicators
- Antibacterial filter
- Hygiene programme
- Adjustable feet
- Delay timer
- 3 baskets
- Turbo drying

### 7 programmes

- Eco
- Auto
- Hygiene Pro
- Super
- Delicate
- Quick
- Prewash

### Energy consumption

Energy consumption per 100 cycles: **76kwh**  
 Eco programme water consumption: **9L**

### Energy efficiency rating

- Energy rating: **E**

### Technical specification

Rated electrical power: **1.9kW**  
 Power cord length: **165cm**  
 Noise Level: **45db**  
 Noise Class: **C**

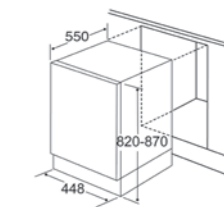

**CDI6121**  
 • 60cm Integrated Dishwasher  
 • 13 place settings  
 • 5 programmes  
 • Delay timer  
 Details on **p105**



**CDI6241**  
 • 60cm Integrated Dishwasher  
 • 15 place settings  
 • 7 programmes  
 • Turbo drying  
 Details on **p105**



**CDI6371**  
 • 60cm Integrated Dishwasher  
 • 15 place settings  
 • 8 programmes  
 • Turbo drying  
 Details on **p106**

## Product specific features

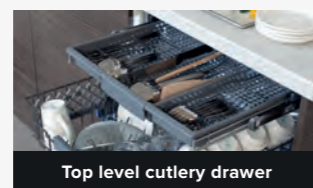
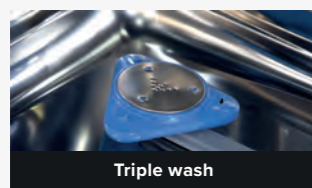



## CDI6121

60cm Integrated Dishwasher

### Features

- 13 place settings
- 5 programmes
- Delay timer
- LED info dot feature
- Half load
- White LED indicators
- Antibacterial filter
- Hygiene programme
- Adjustable feet
- Aquazone

### 5 programmes

- Eco
- Hygiene
- Super
- Quick
- Prewash

### Energy consumption

Energy consumption per 100 cycles: **94kwh**  
Eco programme water consumption: **9L**

### Energy efficiency rating

- Energy rating: **E**

### Technical specification

Rated electrical power: **1.9kW**  
Power cord length: **165cm**  
Noise Level: **49db**  
Noise Class: **C**

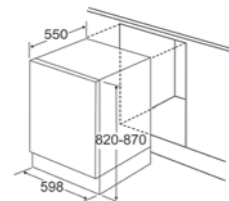

## CDI6241

60cm Integrated Dishwasher

### Features

- 15 place settings
- 7 programmes
- LED info dot feature
- Half load
- White LED indicators
- Antibacterial filter
- Hygiene programme
- Adjustable feet
- Aquazone
- Delay timer
- Turbo drying

### 7 programmes

- Eco
- Intensive
- Hygiene Pro
- Super
- Delicate
- Quick
- Prewash

### Energy consumption

Energy consumption per 100 cycles: **97kwh**  
Eco programme water consumption: **9L**

### Energy efficiency rating

- Energy rating: **E**

### Technical specification

Rated electrical power: **1.9kW**  
Power cord length: **165cm**  
Noise Level: **45db**  
Noise Class: **C**

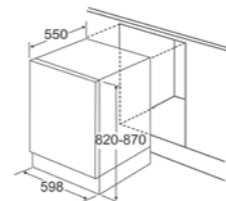

## CDI6371

60cm Integrated Dishwasher

### Features

- 15 place settings
- 8 programmes
- 3 spray levels
- LED info dot feature
- Half load
- White LED indicators
- Antibacterial filter
- Hygiene programme
- Adjustable feet
- Aquazone
- Delay timer
- Steam wash
- BLDC motor
- Direct wash
- Triple wash
- Turbo drying

### 8 programmes

- Eco
- Smart
- Steam wash
- Hygiene Pro
- Super
- Duel Pro Wash
- Quick
- Mini

### Energy consumption

Energy consumption per 100 cycles: **86kwh**  
Eco programme water consumption: **9L**

### Energy efficiency rating

- Energy rating: **D**

### Technical specification

Rated electrical power: **1.9kW**  
Power cord length: **165cm**  
Noise Level: **44db**  
Noise Class: **B**

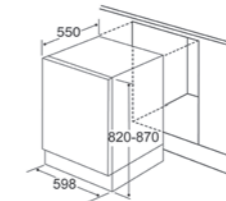

**5**  
**YEARS**  
**PARTS**  
2 YEARS LABOUR



Laundry

## Laundry

Our washing machines make it easy to tackle the laundry. Equipped with the latest programmes and features, they make efficient use of water and energy.

### Our wide range of products

CDA's range consists of integrated washing machines and washer dryers. We are constantly testing, improving and developing our technology to ensure that you benefit from the most energy-efficient and effective appliances possible, whichever model you choose.

### Quick wash

We have developed a super quick wash programme that can complete a cycle in just 15 minutes. Whether you have forgotten to wash your favourite jeans, or need a helping hand with those tedious laundry tasks, the quick wash feature is available on all of our washing machines and washer dryers.

### Advanced technology

High energy ratings are important on appliances like washing machines, as they are used frequently and can make up a large proportion of your energy bills.

Additional digital sensors on our laundry machines work with your spin cycle, water inlet and drying times to adjust the settings to achieve perfect results, every time.

### Save your favourite settings

The **CI361**, **CI327**, **CI381** and **CI981** have an additional **MyChoice** feature, which allows you to save the programmes and options you use most often.

# Quick guide to laundry

The CDA laundry range includes a variety of integrated washing machines and washer dryers.

All CDA washing machines and washer dryers have the following features:

- Robust stainless steel drum
- Safety door lock
- Cold water fill
- Compatible with a full height furniture door, which can be hinged on the right or left

## MyChoice

The **CI361**, **CI327**, **CI381** and **CI981** have an additional MyChoice feature, which allows you to save the programmes and options you use most often.

## Integrated washing machines



### CI361

- **Integrated washing machine**
- 1200rpm spin speed
- 16 programmes
- 6kg wash load
- Details on **p110**



### CI327

- **Integrated washing machine**
- 1400rpm spin speed
- 16 programmes
- 7kg wash load
- Details on **p111**



### CI381

- **Integrated washing machine**
- 1400rpm spin speed
- 16 programmes
- 8kg wash load
- Details on **p111**

## Integrated washer dryers



### CI981

- **Integrated washer dryer**
- 1400rpm spin speed
- 16 programmes
- 8kg wash load
- Details on **p112**

## Integrated washing machines



### CI361

Integrated washing machine

#### Features

- 1200rpm spin speed
- 16 programmes
- 6kg wash load
- Delay timer
- Variable spin speed
- Variable wash
- 15 minute rapid wash
- Delicates wash
- Wool wash
- White LED display
- Safety key lock
- **MyChoice**
- Sport wash
- Extra rinse function
- Acoustic signal for end of programme
- Over-flow protection

Available in white

#### Energy consumption

Energy Consumption per 100 cycles: **74kwh**  
Water consumption per weighted cycle: **43L**

#### Energy efficiency rating

- Energy rating: E

#### Technical specification

Rated electrical power: **2kW**  
Power supply required: **13A**  
Noise level: **76db**  
Spin Class: **C**  
Noise emission class: **B**

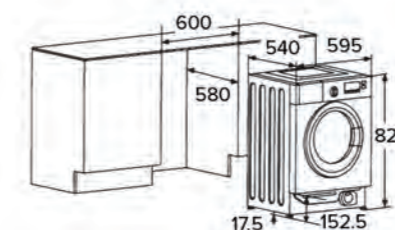



## Integrated washing machines



### CI327

Integrated washing machine

#### Features

- 1400rpm spin speed
- 16 programmes
- 7kg wash load
- White LED display
- Delay timer
- Variable spin speed
- Variable wash temperature
- Overflow protection
- Foam control
- Brushless motor
- Child lock
- **MyChoice**
- 15 minute rapid wash
- Extra rinse function
- Safety key lock
- Acoustic signal for end of programme

Available in white

#### Energy consumption

Energy Consumption per 100 cycles: **52kwh**  
Water consumption per weighted cycle: **45L**

#### Energy efficiency rating

- Energy rating: B

#### Technical specification

Rated electrical power: **2kW**  
Power supply required: **13A**  
Noise level: **76db**  
Spin Class: **B**  
Noise emission class: **B**

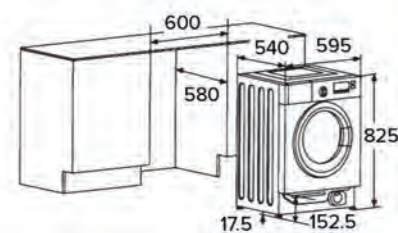

### CI381

Integrated washing machine

#### Features

- 1400rpm spin speed
- 16 programmes
- 8kg wash load
- Delay timer
- Variable spin speed
- Variable wash temperature
- Over-flow protection
- Brushless motor
- 15 minute rapid wash
- Delicates wash
- Wool wash
- White LED display
- Safety key lock
- **MyChoice**
- Sport wash
- Extra rinse function
- Acoustic signal for end of programme

Available in white

#### Energy consumption

Energy Consumption per 100 cycles: **55kwh**  
Water consumption per weighted cycle: **48L**

#### Energy efficiency rating

- Energy rating: B

#### Technical specification

Rated electrical power: **2kW**  
Power supply required: **13A**  
Noise level: **76db**  
Spin Class: **B**  
Noise emission class: **B**

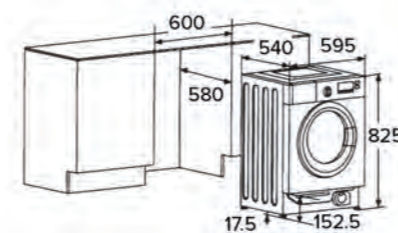

## Integrated washer dryers



### CI981

Integrated washer dryer

#### Features

- 1400rpm spin speed
- 16 programmes
- 8kg wash load
- 6kg dry load
- Delay timer
- Variable spin speed
- Variable wash temperature
- 15 minute rapid wash
- Delicates setting
- **MyChoice**
- White LED display
- Extra rinse function
- Acoustic signal for end of programme
- Condensing dryer
- Safety key lock
- Balance control
- Over-flow protection

Available in white

#### Energy consumption

Energy Consumption per 100 cycles: **55kwh**  
Energy Consumption per 100 cycles (washing and drying): **360kwh**  
Water consumption per weighted cycle: **48L**  
Water consumption per weighted cycle (washing and drying): **90L**

#### Energy efficiency rating

- Energy rating: (Washing only) B
- Energy rating (washing and drying): (Washing and Drying) E

#### Technical specification

Rated electrical power: **2kW**  
Power supply required: **13A**  
Noise level: **76db**  
Spin Class: **B**  
Noise emission class: **B**

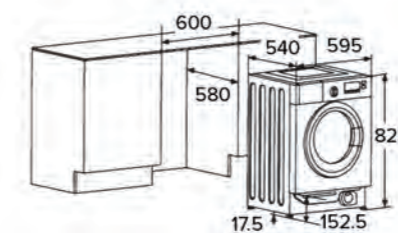

5  
YEAR  
PARTS  
2 YEAR LABOUR



## Sinks

The CDA sink range includes inset and undermount options in stainless steel, composite and ceramic, with styles that complement both contemporary and traditional kitchens.

### Composite

Our composite sink range can withstand temperatures of up to 280°C. Made from a mixture of quartz or granite blended with acrylic resin for durability, our composite sinks are hard-wearing and combine the natural look of stone with the benefits of a modern material.

### Seamless finish

If you are looking for a heavy-grade, minimally styled inset sink, the **KVF21** and **KVF22** are designed to fit flush with your worktops, creating a stylish and contemporary look. Alternatively, the entire undermount sink range offers a seamless finish.

### Ceramic

Made from incredibly robust, fine fireclay with a hard, glossy finish, these sinks are easy to clean and extremely durable. Our choice of styles includes contemporary single or one-and-a-half bowl sinks, traditional Belfast styles and even ceramic undermount sinks. Our ceramic sinks are traditionally made, and each one has individual characteristics. The natural materials used create unique marks and patterns, giving each unit real character.

# Quick guide to inset sinks

The CDA range of sinks includes stainless steel, ceramic and composite models.

Most CDA sinks are supplied with pipework and have large 3.5" strainer wastes.

Inset sinks make a bold statement, with many offering built-in draining options. The range of materials are designed to complement any worktop surface.

## Stainless steel



**KR20**  
 • 1 bowl round drainer  
 Details on [p120](#)



**KR21**  
 • 1 bowl round sink  
 Details on [p120](#)



**KA30**  
 • Compact 1 bowl sink  
 • Reversible  
 Details on [p123](#)



**KA32**  
 • 1.5 bowl sink  
 • Reversible  
 Details on [p123](#)



**KA72**  
 • 1.5 bowl sink  
 • Reversible  
 Details on [p126](#)



**KA80**  
 • 1 bowl sink  
 • Reversible  
 Details on [p126](#)



**CCP3**  
 • 2 bowl corner sink  
 • Polished finish  
 Details on [121](#)



**KA20**  
 • Compact 1 bowl sink  
 • Reversible  
 Details on [p121](#)



**KA21**  
 • 1 bowl sink  
 • Reversible  
 Details on [p122](#)



**KA22**  
 • 1.5 bowl sink  
 • Reversible  
 Details on [p122](#)



**KA55**  
 • 1 bowl sink with mini drainer  
 • Reversible  
 Details on [p124](#)



**KA50**  
 • Compact 1 bowl sink  
 • Reversible  
 Details on [p124](#)



**KA52**  
 • 1.5 bowl sink  
 • Reversible  
 Details on [p125](#)



**KA71**  
 • Large 1 bowl sink  
 • Reversible  
 Details on [p125](#)



**KA82**  
 • 1.5 bowl sink  
 • Reversible  
 Details on [p127](#)



**KVF21R/L**  
 • 1 bowl flush-fit sink  
 • Slim top profile  
 Details on [p128](#)



**KVF22R/L**  
 • 1.5 bowl flush-fit sink  
 • Slim top profile  
 Details on [p128](#)

## Composite



**AS1**  
 • Composite 1 bowl sink  
 • Composite granite construction  
 • Reversible  
 • Available in white or cream  
 Details on [p129](#)



**AS2**  
 • Composite 1.5 bowl sink  
 • Composite granite construction  
 • Reversible  
 • Available in white or cream  
 Details on [p129](#)



**KG81**  
 • Composite 1 bowl sink with steel drainer bars  
 • Granite/quartz construction  
 • Available in anthracite or graphite  
 • Exclusive strainer design  
 Details on [p132](#)



**KG82**  
 • Composite 1.5 bowl sink with steel drainer bars  
 • Granite/quartz construction  
 • Available in anthracite or graphite  
 • Exclusive strainer design  
 Details on [p132](#)



**KG43**  
 • Composite 1 bowl sink  
 • Granite/quartz construction  
 • Exclusive strainer design  
 Details on [p130](#)



**KG44**  
 • Composite 1.5 bowl sink  
 • Granite/quartz construction  
 • Exclusive strainer design  
 Details on [p130](#)



**KG73**  
 • Composite 1 bowl sink  
 • Granite/quartz construction  
 • Available in anthracite or graphite  
 • Exclusive strainer design  
 Details on [p131](#)



**KG74**  
 • Composite 1.5 bowl sink  
 • Granite/quartz construction  
 • Available in anthracite or graphite  
 • Exclusive strainer design  
 Details on [p131](#)

## Ceramic



**KC10**  
 • Ceramic Belfast sink  
 • Fireclay construction  
 Details on [p133](#)



**KC11**  
 • Ceramic Belfast style sink  
 • Fireclay construction  
 Details on [p133](#)



**KC12**  
 • Ceramic Belfast style double bowl sink  
 • Fireclay construction  
 Details on [p134](#)



**KC23**  
 • Ceramic 1 bowl sink  
 • Heavy duty  
 • Reversible  
 Details on [p134](#)



**KC24**  
 • Ceramic 1.5 bowl sink  
 • Heavy duty  
 • Reversible  
 Details on [p135](#)



**KC73**  
 • Ceramic 1 bowl sink  
 • 1 bowl sink  
 • Heavy duty  
 • Reversible  
 Details on [p135](#)



**KC74**  
 • Ceramic 1.5 bowl sink  
 • Heavy duty  
 • Reversible  
 Details on [p136](#)

# Quick guide to undermount sinks

If you are looking for something a little more streamlined, then an undermount sink is the way to go. The sink is designed to fit with your worktops overlapping the edges, for a seamless finish.

You can still have the option of steel, ceramic or composite. You needn't compromise on size either, with generous one-and-a-half bowl sizes available.

## Stainless steel



### KCC21

- **0.5 bowl undermount sink**
- Polished finish
- Easy fixing system
- Details on [p138](#)



### KCC22

- **3/4 bowl undermount sink**
- Polished finish
- Easy fixing system
- Details on [p138](#)



### KCC23

- **1 bowl undermount sink**
- Polished finish
- Easy fixing system
- Details on [p139](#)



### KCC24

- **Rectangular 1 bowl undermount sink**
- Polished finish
- Easy fixing system
- Details on [p139](#)



### KCC27

- **1.5 bowl undermount sink**
- Noise-deadening pads
- Easy fixing system
- Details on [p140](#)



### KCC28

- **1.5 bowl undermount sink**
- Noise-deadening pads
- Easy fixing system
- Details on [p140](#)



### KSC21

- **0.5 bowl undermount sink**
- Noise-deadening pads
- Easy fixing system
- Details on [p141](#)



### KSC22

- **3/4 bowl undermount sink**
- Noise-deadening pads
- Details on [p141](#)



### KSC23

- **1 bowl undermount sink**
- Noise-deadening pads
- Details on [p142](#)



### KSC24

- **1 bowl undermount sink**
- Noise-deadening pads
- Details on [p142](#)



### KSC25

- **Large 1 bowl undermount sink**
- Noise-deadening pads
- Details on [p143](#)



### KVC30R/L

- **1.5 bowl undermount sink**
- Noise-deadening pads
- Details on [p143](#)



### KVC35R/L

- **1.5 bowl undermount sink**
- Noise-deadening pads
- Details on [p144](#)

## Composite



### KMG24

- **1 bowl undermount/inset sink**
- Tough and hygienic
- Granite/quartz construction
- Available in anthracite or graphite
- Details on [p145](#)



### KMG31

- **1.5 bowl undermount/inset sink**
- Tough and hygienic
- Granite/quartz construction
- Reversible
- Available in anthracite or graphite
- Details on [p145](#)

## Ceramic



### KC42

- **Ceramic undermount/inset 1 bowl sink**
- Fireclay construction
- Details on [p146](#)



## Inset sinks

In contemporary and traditional finishes, our inset sinks elegantly combine stunning design with versatile functionality.

### Stainless steel sinks



#### KR20

Stainless steel round drainer

##### Features

- Polished finish

**Available in** stainless steel

##### Accessories

- Waste kit
- Plumbing pack

##### Optional accessories

- Waste disposer, AKD01/AKD02
- Space-saver plumbing pack, PP1

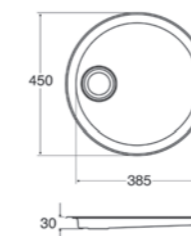

#### KR21

Stainless steel round single bowl sink

##### Features

- Polished finish
- Fits in 450mm base unit

**Available in** stainless steel

##### Accessories

- Waste kit
- Plumbing pack

##### Optional accessories

- Waste disposer, AKD01/AKD02
- Space-saver plumbing pack, PP1

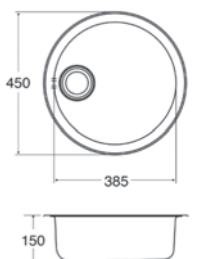

## Stainless steel sinks



### CCP3

Stainless steel corner double bowl sink

#### Features

- Polished finish
- 1mm heavy gauge stainless steel construction

Available in stainless steel

#### Optional accessories

- Waste disposer, AKD01/AKD02
- Space-saver plumbing pack, PP2

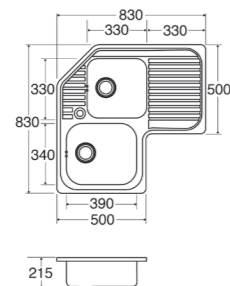

### KA20

Stainless steel compact single bowl sink

#### Features

- Polished finish
- Reversible
- Fits in 450mm base unit

Available in stainless steel

#### Accessories

- Waste kit
- Plumbing pack

#### Optional accessories

- Waste disposer, AKD01/AKD02
- Space-saver plumbing pack, PP1

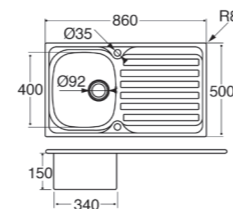

### KA21

Stainless steel single bowl sink

#### Features

- Polished finish
- Reversible
- Fits in 450mm base unit

Available in stainless steel

#### Accessories

- Waste kit
- Plumbing pack

#### Optional accessories

- Waste disposer, AKD01/AKD02
- Space-saver plumbing pack, PP1

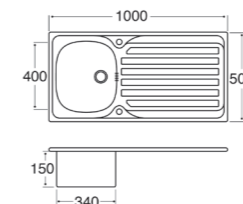

### KA22

Stainless steel one-and-a-half bowl sink

#### Features

- Polished finish
- Reversible
- Fits in 600mm base unit

Available in stainless steel

#### Accessories

- Waste kit
- Plumbing pack

#### Optional accessories

- Waste disposer, AKD01/AKD02
- Space-saver plumbing pack, PP2

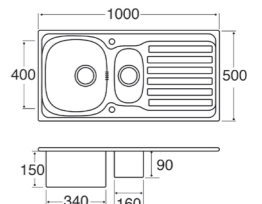



### KA30

Stainless steel compact single bowl sink

**Features**

- Polished finish
- Reversible
- Fits in 500mm base unit

**Available in** stainless steel

**Accessories**

- Waste kit
- Plumbing pack

**Optional accessories**

- Waste disposer, AKD01/AKD02
- Space-saver plumbing pack, PP1

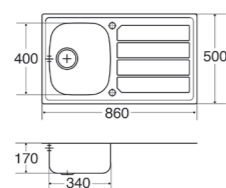

### KA32

Stainless steel one-and-a-half bowl sink

**Features**

- Polished finish
- Reversible
- Fits in 600mm base unit

**Available in** stainless steel

**Accessories**

- Waste kit
- Plumbing pack

**Optional accessories**

- Waste disposer, AKD01/AKD02
- Space-saver plumbing pack, PP2

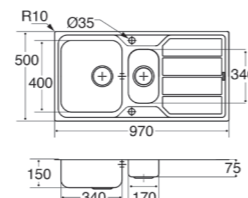

### KA55

Stainless steel single bowl sink with mini drainer

**Features**

- Polished finish
- Reversible
- Fits in 450mm base unit

**Available in** stainless steel

**Accessories**

- Waste kit
- Plumbing pack

**Optional accessories**

- Waste disposer, AKD01/AKD02
- Space-saver plumbing pack, PP1

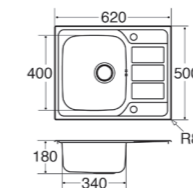

### KA50

Stainless steel compact single bowl sink

**Features**

- Polished finish
- Reversible
- Fits in 450mm base unit

**Available in** stainless steel

**Accessories**

- Waste kit
- Plumbing pack

**Optional accessories**

- Waste disposer, AKD01/AKD02
- Space-saver plumbing pack, PP1

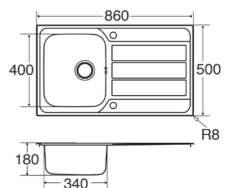



## KA52

Stainless steel one-and-a-half bowl sink

### Features

- Polished finish
- Reversible
- Fits in 600mm base unit

**Available in** stainless steel

### Accessories

- Waste kit
- Plumbing pack

### Optional accessories

- Waste disposer, AKD01/AKD02
- Space-saver plumbing pack, PP2

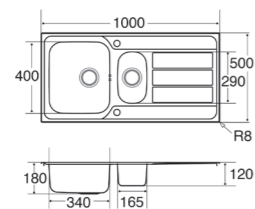

## KA71

Stainless steel large single bowl sink

### Features

- Polished finish
- Reversible
- Extra large bowl
- Fits in 600mm base unit

**Available in** stainless steel

### Accessories

- Waste kit
- Plumbing pack

### Optional accessories

- Waste disposer, AKD01/AKD02
- Space-saver plumbing pack, PP1

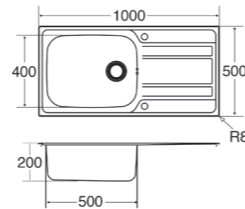

## KA72

Stainless steel one-and-a-half bowl sink

### Features

- Polished finish
- Reversible
- Fits in 600mm base unit

**Available in** stainless steel

### Accessories

- Waste kit
- Plumbing pack

### Optional accessories

- Waste disposer, AKD01/AKD02
- Space-saver plumbing pack, PP2

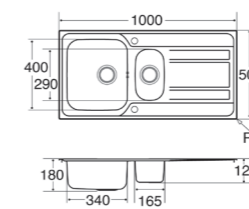

## KA80

Stainless steel single bowl sink

### Features

- Polished, satinised finish for an extra-smooth, easy-to-clean surface
- Reversible
- Fits in 500mm base unit
- Larger bowl
- Recessed water-safe perimeter profile

**Available in** stainless steel

### Accessories

- Waste kit
- Plumbing pack

### Optional accessories

- Waste disposer, AKD01/AKD02
- Space-saver plumbing pack, PP1

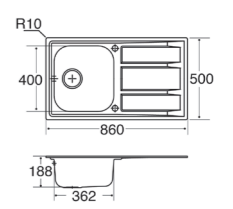



## Stainless steel sinks



### KA82

Stainless steel one-and-a-half bowl sink

#### Features

- Polished, satinised finish for an extra-smooth, easy-to-clean surface
- Reversible
- Fits in 600mm base unit
- Recessed water-safe perimeter profile

Available in stainless steel

#### Accessories

- Waste kit
- Plumbing pack

#### Optional accessories

- Waste disposer, AKD01/AKD02
- Space-saver plumbing pack, PP2

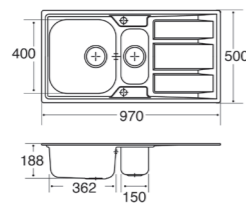

## Stainless steel flush-fit sinks



KVF21R



KVF21L

### KVF21

Single bowl flush-fit sink

#### Features

- Extra-large bowl
- Flush-fit, slim top profile
- Fits in 600mm base unit
- 1mm heavy gauge stainless steel construction
- Noise-deadening pads

Available in stainless steel - right-hand drainer, KVF21R; stainless steel - left-hand drainer, KVF21L

#### Accessories

- Concealed overflow
- Waste kit
- Plumbing pack

#### Optional accessories

- Waste disposer, AKD01/AKD02
- Space-saver plumbing pack, PP1

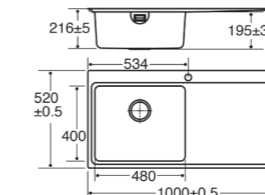

KVF22R



KVF22L

### KVF22

One-and-a-half bowl flush-fit sink

#### Features

- Flush-fit, slim top profile
- Fits in 600mm base unit
- 1mm heavy gauge stainless steel construction
- Noise-deadening pads

Available in stainless steel - right-hand drainer, KVF22R; stainless steel - left-hand drainer, KVF22L

#### Accessories

- Concealed overflow
- Waste kit
- Plumbing pack

#### Optional accessories

- Waste disposer, AKD01/AKD02
- Space-saver plumbing pack, PP2

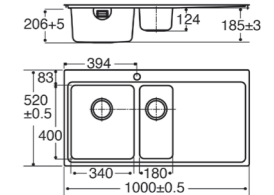

## Composite sinks



White



Cream

### AS1

Composite single bowl sink

#### Features

- Composite granite construction
- Scratch resistant
- Reversible
- Fits in 450mm base unit

**Available in** white, cream

#### Accessories

- Waste kit
- Plumbing pack

#### Optional accessories

- Waste disposer, AKD01/AKD02
- Space-saver plumbing pack, PP1

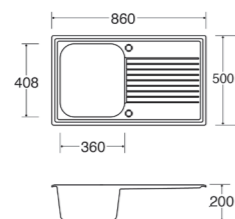

White



Cream

### AS2

Composite one-and-a-half bowl sink

#### Features

- Composite granite construction
- Scratch resistant
- Reversible
- Fits in 600mm base unit

**Available in** white, cream

#### Accessories

- Waste kit
- Plumbing pack

#### Optional accessories

- Waste disposer, AKD01/AKD02
- Space-saver plumbing pack, PP2

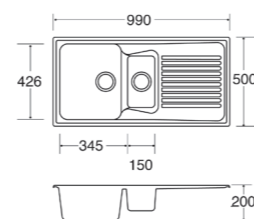

### KG43

Composite single bowl sink

#### Features

- Granite/quartz construction
- Scratch resistant
- Tough and hygienic
- Super smooth metallic finish
- Reversible
- Fits in 600mm base unit
- Exclusive strainer design

**Available in** anthracite

#### Accessories

- Concealed overflow
- Waste kit
- Plumbing pack

#### Optional accessories

- Waste disposer, AKD01/AKD02
- Space-saver plumbing pack, PP1

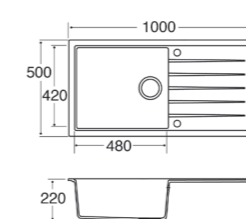

### KG44

Composite one-and-a-half bowl sink

#### Features

- Granite/quartz construction
- Scratch resistant
- Tough and hygienic
- Super smooth metallic finish
- Reversible
- Fits in 600mm base unit
- Exclusive strainer design

**Available in** anthracite

#### Accessories

- Concealed overflow
- Waste kit
- Plumbing pack

#### Optional accessories

- Waste disposer, AKD01/AKD02
- Space-saver plumbing pack, PP2

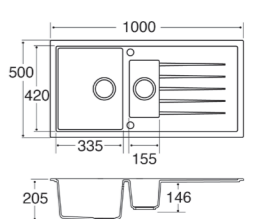



Anthracite



Graphite

## KG73

Composite single bowl sink

### Features

- Granite/quartz construction
- Scratch resistant
- Tough and hygienic
- Super smooth metallic finish
- Reversible
- Fits in 600mm base unit
- Exclusive strainer design

Available in anthracite, graphite

### Accessories

- Concealed overflow
- Waste kit
- Plumbing pack

### Optional accessories

- Waste disposer, AKD01/AKD02
- Space-saver plumbing pack, PP1

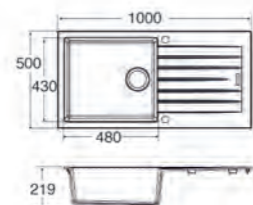

Anthracite



Graphite

## KG74

Composite one-and-a-half bowl sink

### Features

- Granite/quartz construction
- Scratch resistant
- Tough and hygienic
- Super smooth metallic finish
- Reversible
- Fits in 600mm base unit
- Exclusive strainer design

Available in anthracite, graphite

### Accessories

- Concealed overflow
- Waste kit
- Plumbing pack

### Optional accessories

- Waste disposer, AKD01/AKD02
- Space-saver plumbing pack, PP2

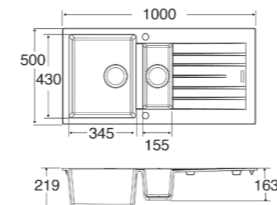

Anthracite



Graphite

## KG81

Composite single bowl sink with stainless steel drainer bars

### Features

- Granite/quartz construction
- Scratch resistant
- Tough and hygienic
- Super smooth metallic finish
- Reversible
- Fits in 600mm base unit
- Stainless steel drainer bars
- Exclusive strainer design

Available in anthracite, graphite

### Accessories

- Concealed overflow
- Waste kit
- Plumbing pack

### Optional accessories

- Waste disposer, AKD01/AKD02
- Space-saver plumbing pack, PP1

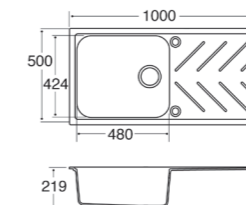

Anthracite



Graphite

## KG82

Composite one-and-a-half bowl sink with stainless steel drainer bars

### Features

- Granite/quartz construction
- Scratch resistant
- Tough and hygienic
- Super smooth metallic finish
- Reversible
- Fits in 600mm base unit
- Stainless steel drainer bars
- Exclusive strainer design

Available in anthracite, graphite

### Accessories

- Concealed overflow
- Waste kit
- Plumbing pack

### Optional accessories

- Waste disposer, AKD01/AKD02
- Space-saver plumbing pack, PP2

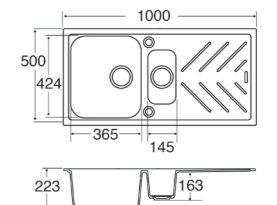

## Ceramic sinks



### KC10

Ceramic Belfast sink

#### Features

- Classic design
- Fireclay construction
- Suitable for over or under mounting

Available in white

#### Accessories

- Waste kit
- Plumbing pack

#### Optional accessories

- Space-saver plumbing pack, PP1

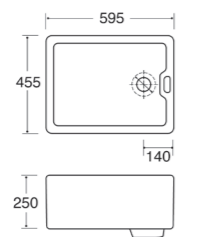
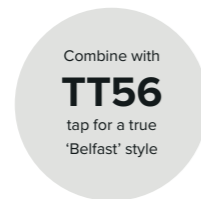

PLEASE NOTE: DIMENSIONS MAY DIFFER BY UP TO 5%



### KC11

Ceramic Belfast style sink

#### Features

- Classic design
- Fireclay construction

Available in white

#### Accessories

- Waste kit
- Plumbing pack

#### Optional accessories

- Waste disposer and adaptor, AKD01/ AKD02 and AKD03
- Space-saver plumbing pack, PP1

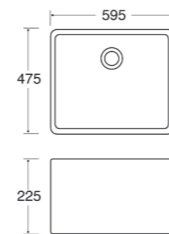

PLEASE NOTE: DIMENSIONS MAY DIFFER BY UP TO 5%



### KC12

Ceramic Belfast style double bowl sink

#### Features

- Classic design
- Fireclay construction

Available in white

#### Accessories

- Waste kit
- Plumbing pack

#### Optional accessories

- Waste disposer and adaptor, AKD01/ AKD02 and AKD03
- Space-saver plumbing pack, PP2

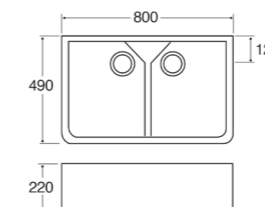

PLEASE NOTE: DIMENSIONS MAY DIFFER BY UP TO 5%



### KC23

Ceramic single bowl sink

#### Features

- Classic design
- Heavy duty
- Reversible
- Fits in 600mm base unit

Available in white

#### Accessories

- Waste kit
- Plumbing pack

#### Optional accessories

- Waste disposer and adaptor, AKD01/ AKD02 and AKD03
- Space-saver plumbing pack, PP1

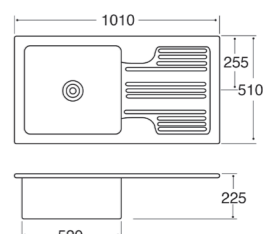

PLEASE NOTE: DIMENSIONS MAY DIFFER BY UP TO 5%

## Ceramic sinks



### KC24

Ceramic one-and-a-half bowl sink

#### Features

- Classic design
- Heavy duty
- Reversible
- Fits in 600mm base unit

Available in white

#### Accessories

- Waste kit
- Plumbing pack

#### Optional accessories

- Waste disposer and adaptor, AKD01/ AKD02 and AKD03
- Space-saver plumbing pack, PP2

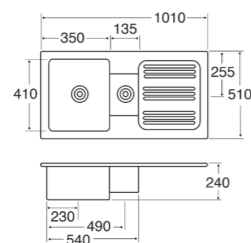

PLEASE NOTE: DIMENSIONS MAY DIFFER BY UP TO 5%



### KC73

Ceramic single bowl sink

#### Features

- Classic design
- Heavy duty
- Large bowl
- Reversible
- Fits in 600mm base unit

Available in white

#### Accessories

- Waste kit
- Plumbing pack

#### Optional accessories

- Waste disposer and adaptor, AKD01/ AKD02 and AKD03
- Space-saver plumbing pack, PP1

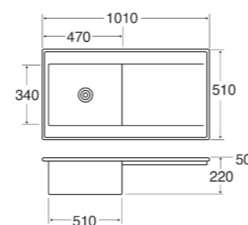

PLEASE NOTE: DIMENSIONS MAY DIFFER BY UP TO 5%



### KC74

Ceramic one-and-a-half bowl sink

#### Features

- Classic design
- Heavy duty
- Reversible
- Fits in 600mm base unit

Available in white

#### Accessories

- Waste kit
- Plumbing pack

#### Optional accessories

- Waste disposer and adaptor, AKD01/ AKD02 and AKD03
- Space-saver plumbing pack, PP2

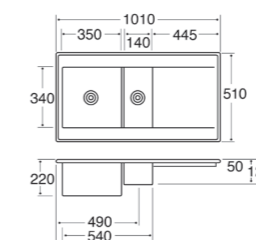

PLEASE NOTE: DIMENSIONS MAY DIFFER BY UP TO 5%



## Undermount sinks

Our undermount sinks blend seamlessly with your worktop surround to create a flawless finish.

### Stainless steel sinks



#### KCC21

Stainless steel undermount half bowl sink

##### Features

- Polished finish
- Easy fixing system
- Noise-deadening pads

**Available in** stainless steel

##### Accessories

- Waste kit
- Plumbing pack

##### Optional accessories

- Waste disposer, AKD01/AKD02
- Space-saver plumbing pack, PP1



#### KCC22

Stainless steel undermount three-quarter bowl sink

##### Features

- Polished finish
- Easy fixing system
- Noise-deadening pads

**Available in** stainless steel

##### Accessories

- Waste kit
- Plumbing pack

##### Optional accessories

- Waste disposer, AKD01/AKD02
- Space-saver plumbing pack, PP1

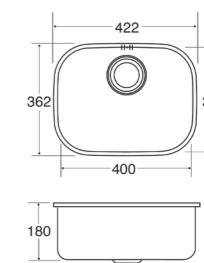

## Stainless steel sinks



### KCC23

Stainless steel undermount single bowl sink

#### Features

- Polished finish
- Easy fixing system
- Noise-deadening pads

**Available in** stainless steel

#### Accessories

- Waste kit
- Plumbing pack

#### Optional accessories

- Waste disposer, AKD01/AKD02
- Space-saver plumbing pack, PP1

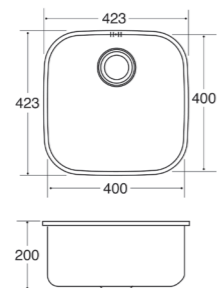

### KCC24

Stainless steel undermount rectangular single bowl sink

#### Features

- Polished finish
- Easy fixing system
- Noise-deadening pads

**Available in** stainless steel

#### Accessories

- Waste kit
- Plumbing pack

#### Optional accessories

- Waste disposer, AKD01/AKD02
- Space-saver plumbing pack, PP1

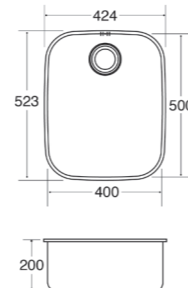

### KCC27

Stainless steel undermount right-hand one-and-a-half bowl sink

#### Features

- Polished finish
- Easy fixing system
- Noise-deadening pads

**Available in** stainless steel

#### Accessories

- Waste kit
- Plumbing pack

#### Optional accessories

- Waste disposer, AKD01/AKD02
- Space-saver plumbing pack, PP2

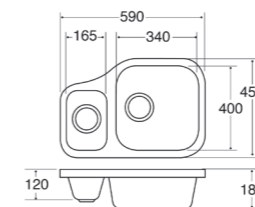

### KCC28

Stainless steel undermount left-hand one-and-a-half bowl sink

#### Features

- Polished finish
- Easy fixing system
- Noise-deadening pads

**Available in** stainless steel,

#### Accessories

- Waste kit
- Plumbing pack

#### Optional accessories

- Waste disposer, AKD01/AKD02
- Space-saver plumbing pack, PP2

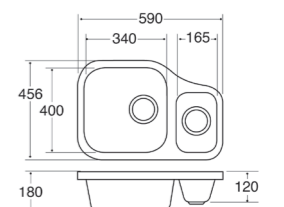



### KSC21

Stainless steel undermount half bowl sink

**Features**

- 1mm heavy gauge stainless steel construction
- Noise-deadening pads
- Square strainer design

**Available in** stainless steel

**Accessories**

- Concealed overflow
- Waste kit
- Plumbing pack

**Optional accessories**

- Space-saver plumbing pack, PP1

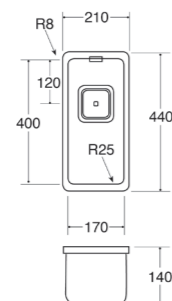

### KSC22

Stainless steel undermount three-quarter bowl sink

**Features**

- 1mm heavy gauge stainless steel construction
- Noise-deadening pads
- Square strainer design

**Available in** stainless steel

**Accessories**

- Concealed overflow
- Waste kit
- Plumbing pack

**Optional accessories**

- Space-saver plumbing pack, PP1

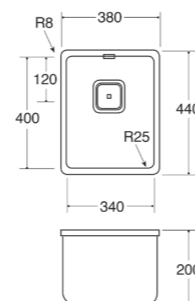

### KSC23

Stainless steel undermount single bowl sink

**Features**

- 1mm heavy gauge stainless steel construction
- Noise-deadening pads
- Square strainer design

**Available in** stainless steel

**Accessories**

- Concealed overflow
- Waste kit
- Plumbing pack

**Optional accessories**

- Space-saver plumbing pack, PP1

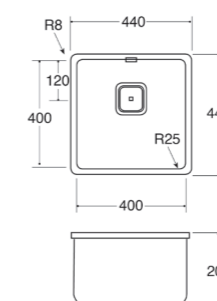

### KSC24

Stainless steel undermount single bowl sink

**Features**

- 1mm heavy gauge stainless steel construction
- Noise-deadening pads
- Square strainer design

**Available in** stainless steel

**Accessories**

- Concealed overflow
- Waste kit
- Plumbing pack

**Optional accessories**

- Space-saver plumbing pack, PP1

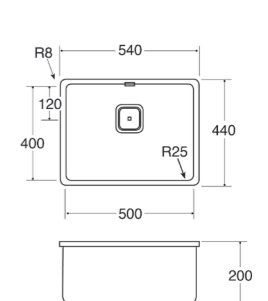



## Stainless steel sinks



### KSC25

Stainless steel undermount large single bowl sink

#### Features

- 1mm heavy gauge stainless steel construction
- Noise-deadening pads
- Square strainer design

**Available in** stainless steel

#### Accessories

- Concealed overflow
- Waste kit
- Plumbing pack

#### Optional accessories

- Space-saver plumbing pack, PP1

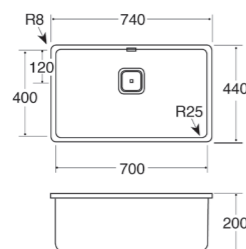

KVC30R



KVC30L

### KVC30

Stainless steel undermount one-and-a-half bowl sink

#### Features

- Satin finish
- Noise-deadening pads
- Exclusive strainer design

**Available in** stainless steel - right-hand half bowl, KVC30R; stainless steel - left-hand half bowl, KVC30L

#### Accessories

- Concealed overflow
- Waste kit
- Plumbing pack

#### Optional accessories

- Waste disposer, AKD01/AKD02
- Space-saver plumbing pack, PP2

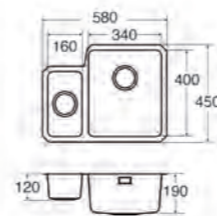

KVC35R



KVC35L

### KVC35

Stainless steel undermount one-and-a-half bowl sink

#### Features

- Satin finish
- Noise-deadening pads
- Exclusive strainer design

**Available in** stainless steel - right-hand half bowl, KVC35R; stainless steel - left-hand half bowl, KVC35L

#### Accessories

- Concealed overflow
- Waste kit
- Plumbing pack

#### Optional accessories

- Waste disposer, AKD01/AKD02
- Space-saver plumbing pack, PP2

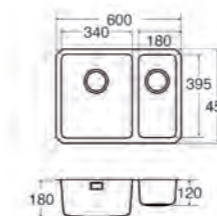

## Composite sinks



Anthracite



Graphite

### KMG24

Composite undermount/inset single bowl sink

#### Features

- Granite/quartz construction
- Tough and hygienic
- Super smooth metallic finish
- Reversible
- Fits in 600mm base unit
- Exclusive strainer design
- Both undermount and inset clips included
- Can be undermount or inset

**Available in** anthracite, graphite

#### Accessories

- Concealed overflow
- Waste kit
- Plumbing pack

#### Optional accessories

- Waste disposer, AKD01/AKD02
- Space-saver plumbing pack, PP1

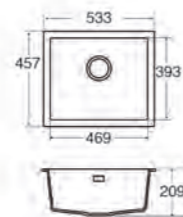

Anthracite



Graphite

### KMG31

Composite undermount/inset one-and-a-half bowl sink

#### Features

- Granite/quartz construction
- Tough and hygienic
- Super smooth metallic finish
- Reversible
- Fits in 600mm base unit
- Exclusive strainer design
- Both undermount and inset clips included
- Can be undermount or inset

**Available in** anthracite, graphite

#### Accessories

- Concealed overflow
- Waste kit
- Plumbing pack

#### Optional accessories

- Waste disposer, AKD01/AKD02
- Space-saver plumbing pack, PP2

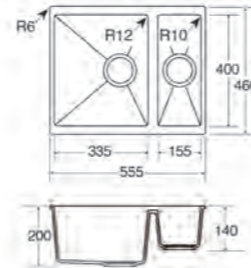

## Ceramic sinks



### KC42

Ceramic undermount/inset half bowl sink

#### Features

- Classic design
- Fireclay construction
- Can be undermount or inset

**Available in** white

#### Accessories

- Waste kit
- Plumbing pack

#### Optional accessories

- Waste disposer and adaptor, AKD01/AKD02 and AKD03
- Space-saver plumbing pack, PP1

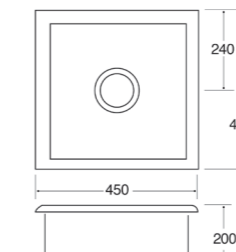

PLEASE NOTE: DIMENSIONS MAY DIFFER BY UP TO 5%

**5**  
YEAR  
PARTS  
2 YEAR LABOUR



Taps

## Taps

Whether it's a simple lever tap or something more sophisticated, if you choose a tap from our 2022 collection you can be sure that it will be beautifully designed.

### Filter tap

Our **TF55** tap filters mains tap water to improve its taste, clarity and odour. Mains water is passed through a cartridge concealed under the sink and is controlled through the tap by a simple lever action.

### Professional chef-style taps

The pull-out spray on some of our contemporary taps can be a useful helping hand. Use the spray for thorough rinsing of fruit and vegetables, for fast defrosting, to fill large vases or buckets, and for countless other kitchen jobs.

### Hot water on demand

Speed up cooking and making hot drinks by installing a **TH102** instant hot water tap. With an under-counter heating tank, this useful kitchen appliance can produce around 1.8 litres of hot water per minute, supporting many culinary tasks.

## Quick guide to taps

The range of taps from CDA covers a wide spectrum of designs, from stylish, functional taps through to cutting-edge, contemporary designer taps that make a bold statement in your kitchen.

### Contemporary taps



- TC10**  
• Standard single lever tap  
Details on p151
- TC15**   
• Classic single lever tap  
Details on p151
- TC20**  
• Standard quarter turn monobloc tap  
Details on p151



- TC61**  
• Single side lever tap with quad spout  
Details on p153
- TC65**  
• Monobloc tap with quad spout  
Details on p154
- TC66**  
• Single side lever tap with quad spout  
Details on p154



- TC28**  
• Contemporary quarter turn monobloc tap  
Details on p152
- TC31**  
• Single side lever tap with swan neck spout  
Details on p152
- TC41**   
• Quarter turn cross handle monobloc tap  
Details on p152
- TC55**   
• Monobloc tap with swan neck spout  
Details on p153
- TC57**  
• Single side lever tap with swan neck spout  
Details on p153



- TC77**   
• Contemporary slant monobloc tap  
Details on p154
- TV5**  
• Contemporary side single lever tap  
Details on p155
- TV6**  
• Round tower single lever tap  
Details on p155
- TV7**  
• Contemporary side single lever tap with swivel spout  
Details on p155
- TV9**   
• Contemporary square side single lever tap  
Details on p156

### Traditional taps



- TT25**   
• Traditional monobloc tap  
Details on p157
- TT41**   
• Traditional turn lever monobloc tap  
Details on p157
- TT50**  
• Traditional dual lever monobloc tap  
Details on p157



- TT56**  
• Traditional quarter turn bridge mixer tap  
Details on p158

### Guidance on minimum operation pressure

Taps with a minimum operating pressure of 0.4Bar, or less, are compatible with low pressure hot water systems.

**Check your supply pressure before purchasing taps requiring 0.5Bar or higher.**

### Filter tap



- TF55**   
• Monobloc filter tap with swan neck spout  
Details on p158

### 3-in-1 tap



- TH102**  
• 3-in-1 instant hot water tap  
Details on p160

### Pull-out taps



- TC56**  
• Monobloc tap with pull-out spout  
Details on p159
- TM1**  
• Contemporary single lever tap with pull-out spray  
Details on p159
- TV11**  
• Single lever tap with black pull-out spray  
Details on p159
- TV14**  
• Single lever tap with pull-out spout  
Details on p160

## Contemporary taps



### TC10

Standard single lever tap

#### Features

- Single flow
- Minimum pressure: **0.5Bar**
- 360°C spout rotation
- Ceramic disc valve

Available in chrome

#### Accessories

- Supplied with flexible tail pipes

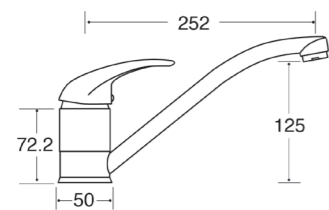

### TC15

Classic single lever tap



#### Features

- Single flow
- Minimum pressure: **0.3Bar**
- Ceramic single lever valve

Available in chrome

#### Accessories

- Supplied with rigid copper tail pipes

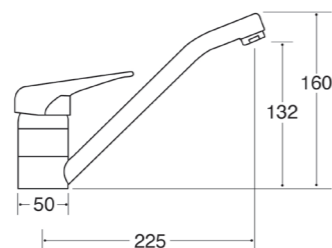

### TC20

Standard quarter turn monobloc tap

#### Features

- Single flow
- Minimum pressure: **0.1Bar**
- 360°C spout rotation
- Ceramic disc 1/4 turn valves

Available in chrome

#### Accessories

- Supplied with flexible tail pipes

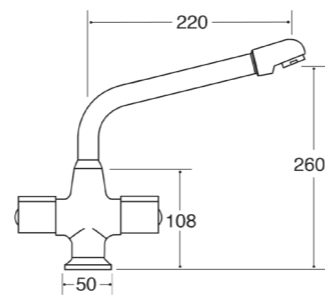

### TC28

Contemporary quarter turn monobloc tap

#### Features

- Single flow
- Minimum pressure: **0.4Bar**
- Ceramic disc 1/4 turn valves
- 360°C spout rotation

Available in chrome

#### Accessories

- Supplied with flexible tail pipes

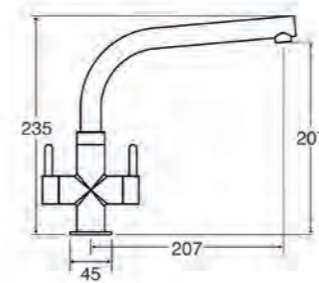

### TC31

Single side lever tap with swan neck spout

#### Features

- Solid stainless steel
- Single flow
- Minimum pressure **0.5Bar**
- Ceramic single lever valve
- 360°C spout rotation

Available in stainless steel

#### Accessories

- Supplied with flexible tail pipes

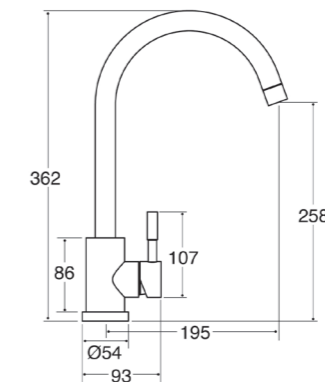

### TC41

Quarter turn cross handle monobloc tap



#### Features

- Dual flow
- Minimum pressure: **0.3Bar**
- Ceramic disc 1/4 turn valves

Available in chrome

#### Accessories

- Supplied with rigid copper tail pipes

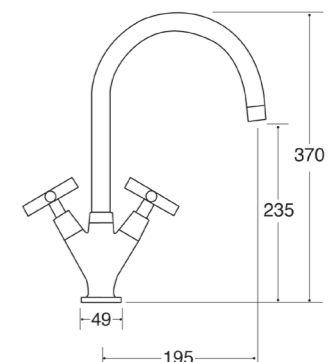

## Contemporary taps



### TC55



Monobloc tap with swan neck spout

#### Features

- Dual flow
- Minimum pressure: **0.3Bar**
- Ceramic disc 1/4 turn valves

Available in chrome, nickel

#### Accessories

- Supplied with rigid copper tail pipes

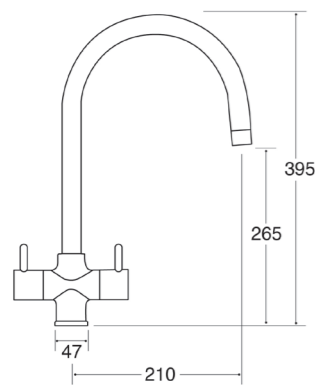

### TC57

Side single lever tap with swan neck spout

#### Features

- Single flow
- Minimum pressure: **0.5Bar**
- Ceramic single lever valve

Available in chrome

#### Accessories

- Supplied with flexible tail pipes

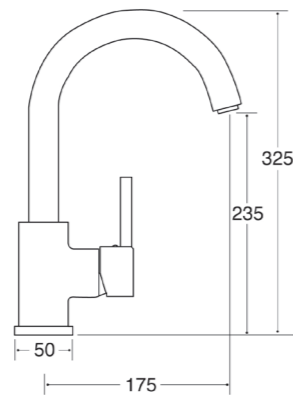

### TC61

Side single lever tap with quad spout

#### Features

- Single flow
- Minimum pressure: **0.5Bar**
- 360° spout rotation
- Ceramic disc valve

Available in stainless steel

#### Accessories

- Supplied with flexible tail pipes

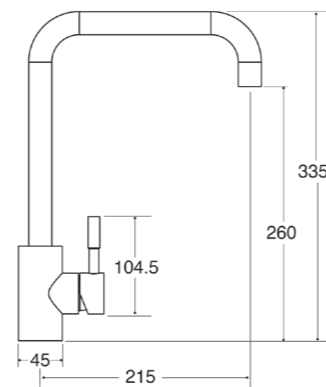

### TC65

Monobloc tap with quad spout

#### Features

- Dual flow
- Minimum pressure: **0.3Bar**
- Ceramic disc 1/4 turn valves

Available in chrome

#### Accessories

- Supplied with rigid copper tail pipes

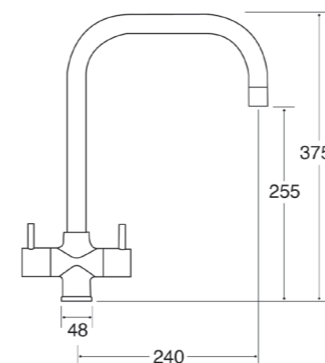

### TC66

Side single lever tap with quad spout

#### Features

- Single flow
- Minimum pressure: **0.5Bar**
- Ceramic single lever valve

Available in chrome

#### Accessories

- Supplied with flexible tail pipes

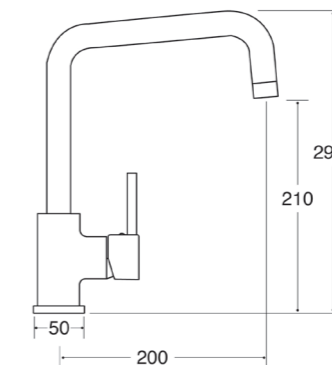

### TC77



Contemporary slant monobloc tap

#### Features

- Single flow
- Minimum pressure: **0.5Bar**
- 360° spout rotation
- Ceramic disc 1/4 turn valves

Available in chrome

#### Accessories

- Supplied with flexible tail pipes

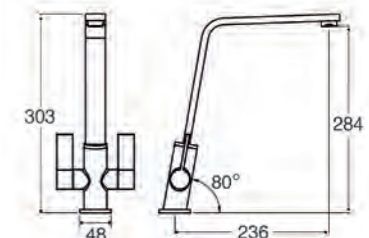

## Contemporary taps



### TV5

Contemporary side single lever tap

#### Features

- Single flow
- Minimum pressure: **0.5Bar**
- 360° spout rotation
- Ceramic disc single lever valve

**Available in** chrome

#### Accessories

- Supplied with flexible tail pipes

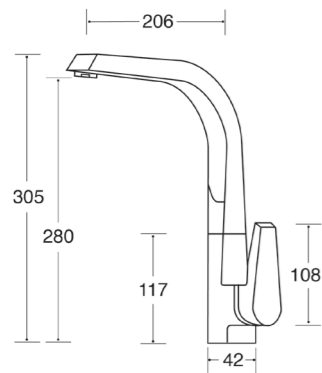

### TV6

Round tower single lever tap

#### Features

- Single flow
- Minimum pressure: **0.5Bar**
- 360° spout rotation
- Ceramic disc single lever valve

**Available in** chrome

#### Accessories

- Supplied with flexible tail pipes

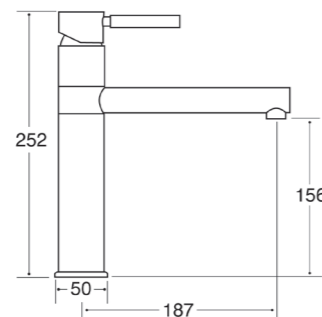

### TV7

Contemporary side single lever tap with swivel spout

#### Features

- Single flow
- Minimum pressure: **0.75Bar**
- 360° spout rotation
- Swivel aerator for precise flow control
- Ceramic disc single lever valve

**Available in** chrome

#### Accessories

- Supplied with flexible tail pipes

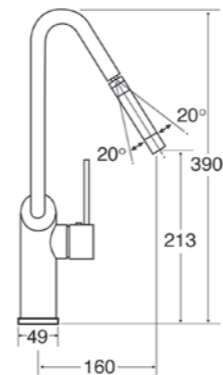

### TV9



Contemporary square side single lever tap

#### Features

- Single flow
- Minimum pressure: **0.5Bar**
- 360° spout rotation
- Ceramic disc single lever valve

**Available in** chrome, matt black

#### Accessories

- Supplied with flexible tail pipes

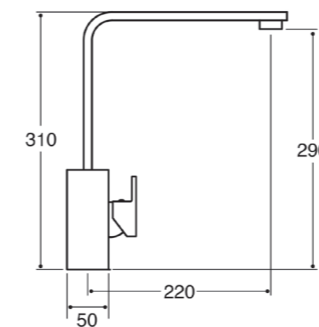

## Traditional taps



### TT25



Traditional monobloc tap

#### Features

- Dual flow
- Minimum pressure: **0.3Bar**
- Compression valves

Available in chrome

#### Accessories

- Supplied with rigid copper tail pipes

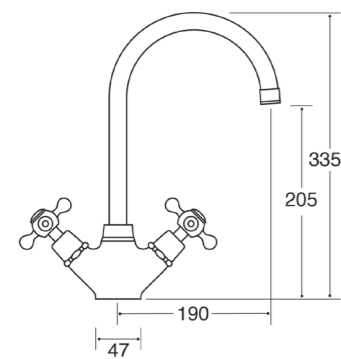

### TT41



Traditional quarter turn lever monobloc tap

#### Features

- Dual flow
- Minimum pressure: **0.2Bar**
- Ceramic disc 1/4 turn valves

Available in chrome, nickel

#### Accessories

- Supplied with rigid copper tail pipes

#### Optional accessories

- Interchangeable handles:
  - White/chrome, **ATT01WH**
  - White/nickel, **ATT02WH**
  - Black/chrome, **ATT01BL**
  - Black/nickel, **ATT02BL**

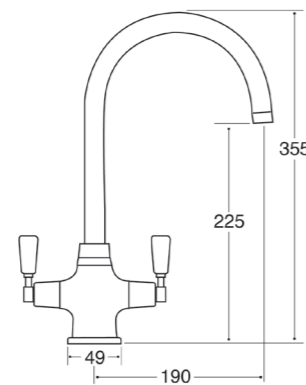

### TT50

Traditional dual lever monobloc tap

#### Features

- Single flow
- Minimum pressure: **0.5Bar**
- 360° spout rotation
- Ceramic disc 1/4 turn valves

Available in chrome

#### Accessories

- Supplied with flexible tail pipes

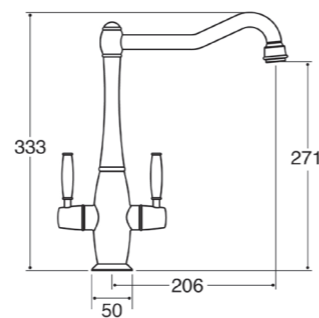

### TT56

Traditional quarter turn bridge mixer tap

#### Features

- Single flow
- Minimum pressure: **0.3Bar**
- Ceramic disc 1/4 turn valves

Available in chrome

#### Accessories

- Supplied with adjustable inlet pipes

#### Optional accessories

- Interchangeable handles:
  - White/chrome, **ATT01WH**
  - Black/chrome, **ATT01BL**

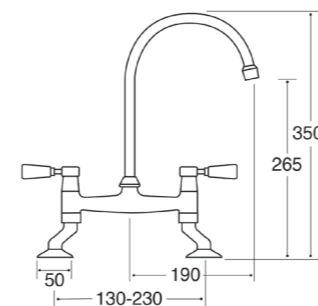

## Filter tap



### TF55



Monobloc filter tap with swan neck spout

#### Features

- Dual flow
- Minimum pressure: **0.4Bar**
- 2 way ceramic disc valve

Available in chrome

#### Accessories

- Filter and installation kit
- Supplied with rigid copper tail pipes

#### Optional accessories

- Replacement filter, **ATF001**

#### Fitting note

- We recommend that you replace the filter every six months

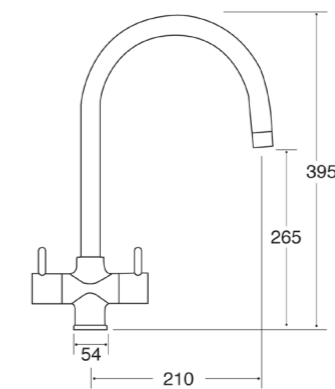



## Pull-out taps



### TC56

Monobloc tap with pull-out spout

#### Features

- Single flow
- Minimum pressure: **0.75Bar**
- Pull-out spout
- Ceramic disc 1/4 turn valves
- Hose extends up to 500mm

**Available in** chrome

#### Accessories

- Supplied with rigid copper tail pipes

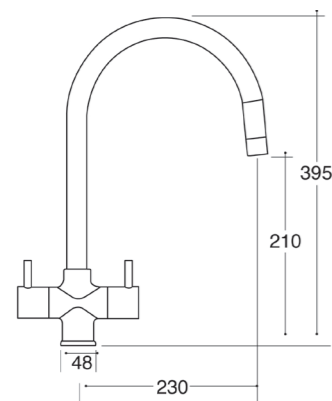

### TM1

Contemporary single lever tap with pull-out spray

#### Features

- Single flow
- Minimum pressure: **1Bar**
- Pull-out spray
- Ceramic disc valve

**Available in** chrome

#### Accessories

- Supplied with flexible tail pipes

#### Fitting note

- Please ensure that your supply pressure is adequate

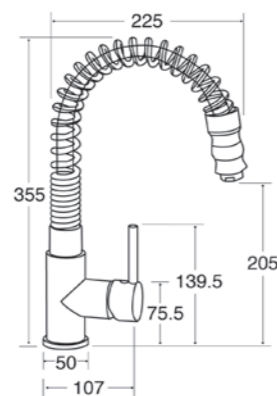

### TV11

Single lever tap with black pull-out spray

#### Features

- Solid stainless steel construction
- Single flow
- Minimum pressure: **1.5Bar**
- Pull-out spray
- 360° spout rotation
- Ceramic disc valve

**Available in** stainless steel

#### Accessories

- Supplied with flexible tail pipes

#### Fitting note

- Please ensure that your supply pressure is adequate

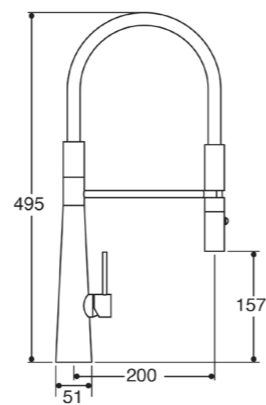

### TV14

Single lever tap with pull-out spout

#### Features

- Single flow
- Minimum pressure: **0.7Bar**
- 360° spout rotation
- Pull-out spray

**Available in** brushed steel/black, brushed steel/grey, brushed steel/white

#### Accessories

- Supplied with flexible tail pipes

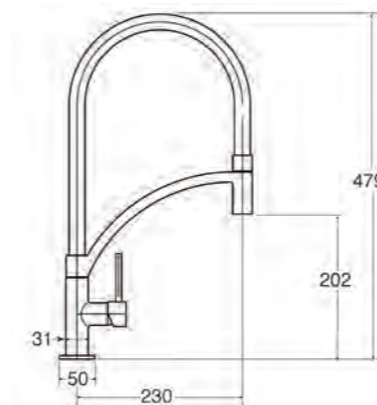

## 3-in-1 tap



### TH102

3-in-1 instant hot water tap



#### Features

- Non-pressurised tank for increased reliability
- Minimum pressure: **1.5Bar**
- Maximum pressure: **5.5Bar**
- 360° spout rotation
- 2L tank
- Filter included
- Rapid 12 minutes initial heat up from cold supply
- Allows several cups of 98°C water to be dispensed
- Easy descaling

**Available in** chrome, brushed steel finish

#### Accessories

- Supplied with flexible tail pipes

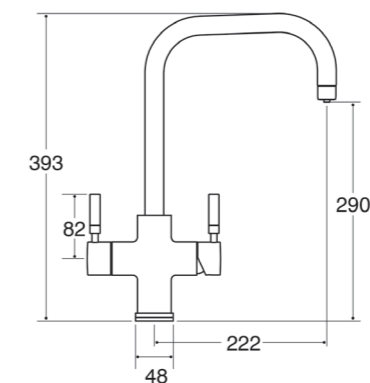

#### Optional accessories

- Replacement filter
- Descaling solution

#### Fitting note

- Please ensure that your supply pressure is adequate
- Please ensure that the drain valve is set as high as possible and is absolutely level
- We recommend changing the filter and descaling the boiler every 6 months

**5**  
**YEARS**  
**PARTS**  
2 YEARS LABOUR

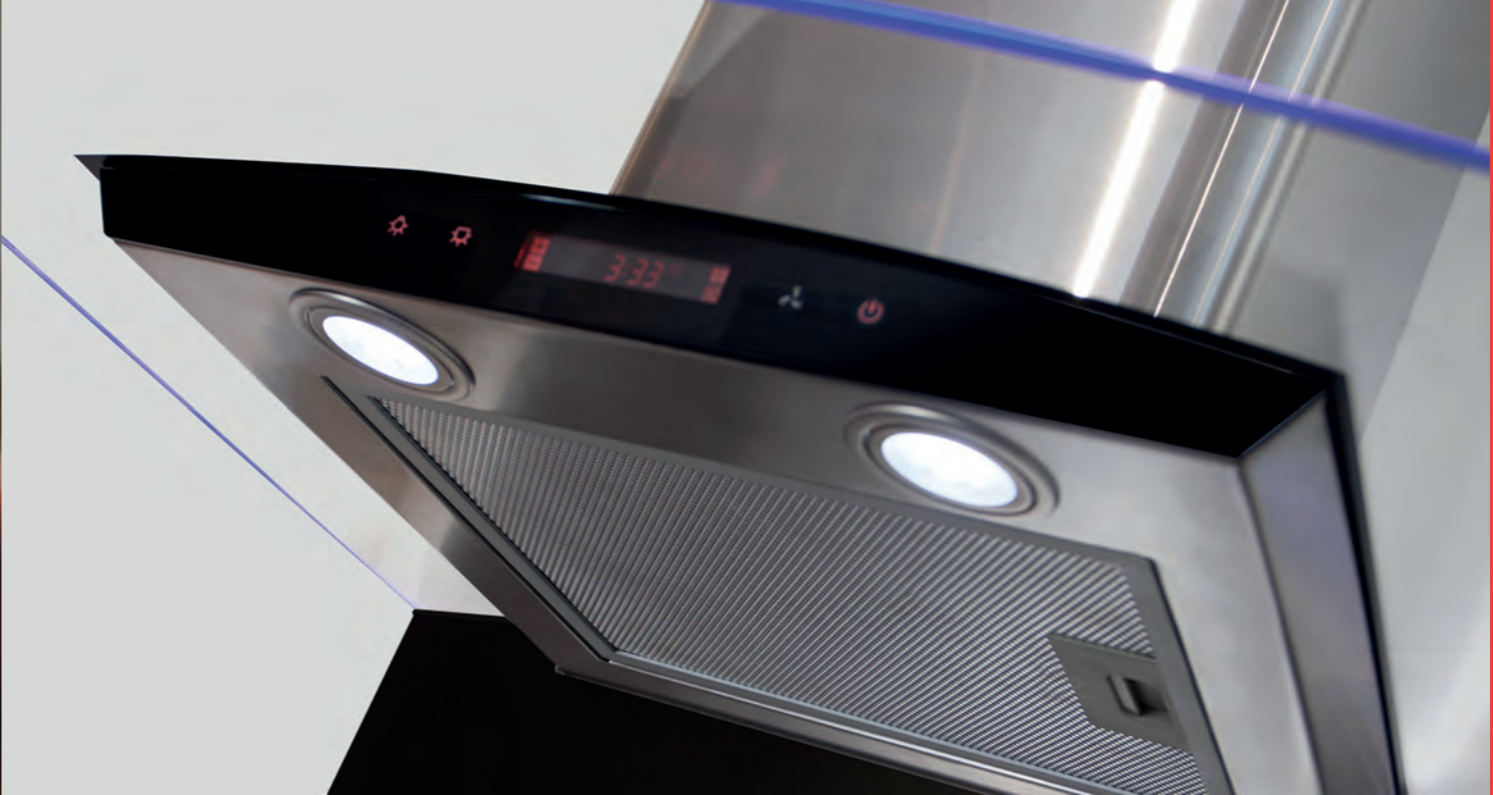

## Accessories

From tap handles and stylish splashbacks to the vital bits that make everything work perfectly, our accessories section provides all the important finishing touches.

### Extractor accessories

Find the ducting kit and charcoal filters for your chosen extractor.

### Sink accessories





Waste dispensers and plumbing packs that are compatible with our sink range.

### Splashbacks

Save your walls from the inevitable splashes and spills with a splashback. Choose from a range of attractive finishes to match the design of your kitchen.

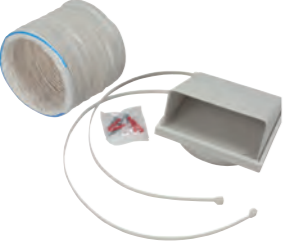
## Extractor accessories

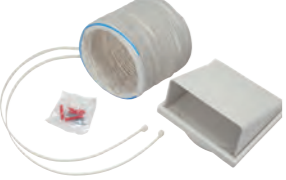
### Ducting kits

Image	Code	Description
	<b>AED 510</b>	<b>125mm x 1m flexible ducting kit</b> <ul style="list-style-type: none"> <li>• White wall outlet</li> <li>• 2 cable ties</li> <li>• 1m flexible hose</li> <li>• Fixing kit</li> </ul>
	<b>AED 560</b>	<b>125mm x 6m flexible ducting kit</b> <ul style="list-style-type: none"> <li>• White wall outlet</li> <li>• 2 cable ties</li> <li>• 6m flexible hose</li> <li>• Fixing kit</li> </ul>
	<b>AED 610</b>	<b>150mm x 1m flexible ducting kit</b> <ul style="list-style-type: none"> <li>• White wall outlet</li> <li>• 2 cable ties</li> <li>• 1m flexible hose</li> <li>• Fixing kit</li> </ul>
	<b>AED 660</b>	<b>150mm x 6m flexible ducting kit</b> <ul style="list-style-type: none"> <li>• White wall outlet</li> <li>• 2 cable ties</li> <li>• 6m flexible hose</li> <li>• Fixing kit</li> </ul>

### Filters

Code	Contents	Compatible with
<b>CHA12</b>	Charcoal filter (pack of 1)	ECN62/72/92, ECP62/72/82/92/102/112, EKPK90, ECNK90, EVX90
<b>CHA15</b>	Charcoal filter (pack of 1)	EIN60, EVA60/70/90, CCA52, CCA72
<b>CHA17</b>	Charcoal filter (pack of 2)	EKP60/70/90, EKN60/70/90
<b>CHA21</b>	Charcoal filter (pack of 2)	EVG6, EVP61/91/101/121, EVPK90
<b>CHA24</b>	Charcoal filter (pack of 2)	ECH61/71/91/101
<b>CHA25</b>	Charcoal filter (pack of 2)	ECPK90

## Extractor accessories

### Filters

Code	Contents	Compatible with
<b>CHA28</b>	Charcoal filter (pack of 2)	HNE8
<b>CHA33</b>	Charcoal filter (pack of 2)	EVQ71
<b>CHA34</b>	Charcoal filter (pack of 2)	CTE61
<b>CHA35</b>	Charcoal filter (pack of 2)	CTE9
<b>CHA36</b>	Charcoal filter (pack of 1)	CST61
<b>CHA37</b>	Charcoal filter (pack of 2)	EXG60/90
<b>GRE1</b>	Acrylic grease filter	EIN60
<b>GRE3M</b>	Metal grease filter	EIN60

## Sink accessories

### Plumbing packs

Code	Contents	Compatible with
<b>PP1</b>	Space-saver plumbing pack	All single bowl sinks
<b>PP2</b>	Space-saver plumbing pack	All one-and-a-half bowl sinks

## Tap accessories

### Tap handles



TT41 tap handles



TT56 tap handles

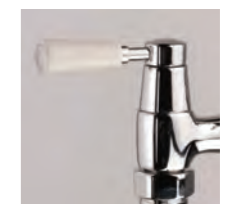

Code	Description	Compatible with
<b>ATT01BL</b>	Black tap handles	TT41CH, TT56CH
<b>ATT01WH</b>	White tap handles	TT41CH, TT56CH
<b>ATT02BL</b>	Black tap handles	TT41NI
<b>ATT02WH</b>	White tap handles	TT41NI

## Splashback accessories

## Splashbacks



Square glass splashback

Square metal splashback

Curved glass splashback

Curved metal splashback

## Accessories

## Square glass splashbacks

Black	Grey	Description
ASG6BL	ASG6GR	600W x 750H* square toughened glass splashback
ASG7BL	ASG7GR	700W x 750H* square toughened glass splashback
ASG9BL	ASG9GR	900W x 750H* square toughened glass splashback
ASG10BL	ASG10GR	1000W x 750H* square toughened glass splashback

## Square metal splashbacks

Black	Stainless steel	Description
CSB6BL	CSB6SS	600W x 750H square metal splashback
CSB7BL	CSB7SS	700W x 750H square metal splashback
CSB9BL	CSB9SS	900W x 750H square metal splashback
CSB10BL	CSB10SS	1000W x 750H square metal splashback

## Curved glass splashbacks

Designed to match the ECP and EKP range of extractors

Black	Grey	Description	Compatible with
ASG62CBL	ASG62CGR	600W x 750H* curved glass splashback	ECP62, EKP60
ASG72CBL	ASG72CGR	700W x 750H* curved glass splashback	ECP72, EKP70
ASG82CBL	ASG82CGR	800W x 750H* curved glass splashback	ECP82
ASG92CBL	ASG92CGR	900W x 750H* curved glass splashback	ECP92
ASG92KBL	ASG92KGR	900W x 750H* curved glass splashback	EKP90
ASG102CBL	ASG102CGR	1000W x 750H* curved glass splashback	ECP102

## Curved metal splashbacks

Designed to match the ECP and EKP range of extractors

Black	Stainless steel	Description	Compatible with
CSB62CBL	CSB62CSS	600W x 750H curved metal splashback	ECP62, EKP60
CSB72CBL	CSB72CSS	700W x 750H curved metal splashback	ECP72, EKP70
CSB92CBL	CSB92CSS	900W x 750H curved metal splashback	ECP92
CSB92KBL	CSB92KSS	900W x 750H curved metal splashback	EKP90

\*Our toughened glass splashbacks are handmade, so dimensions shown may vary by up to 5mm

## Wine cooler accessories

## Wine cooler glass shelves

Our wine cooler glass shelves are perfect for storing smaller items such as bottles and cans

Code	Description	Compatible with
AFG31	Glass shelves (pack of 3)	FWC304, FWC624
AFG61	Glass shelves (pack of 3)	FWC604, FWC881

## Accessories

## Ceramic filter

Code	Description	Compatible with
ATF001	Ceramic filter	TF55

## Flow rate restrictors

Code	Description	Compatible with
ATF002	Flow rate restrictors	All taps with rigid copper tail pipes
ATF003	Flow rate restrictors	All taps with flexible tail pipes

## Hob accessories

Code	Description	Compatible with
AHJ30	Domino joining strip	All stainless steel domino hobs (excludes HE3141)

## Plinth heater

Code	Description
APH02SS	Electric 2kW plinth heater



## Stay up-to-date

You can locate your nearest CDA retailer, register your purchase or contact our customer care team on our website.

From time to time our products are changed, specifications updated and new products launched. Visit our website for all up-to-date information and specifications.

Discover our appliances at [www.cda.eu](http://www.cda.eu)

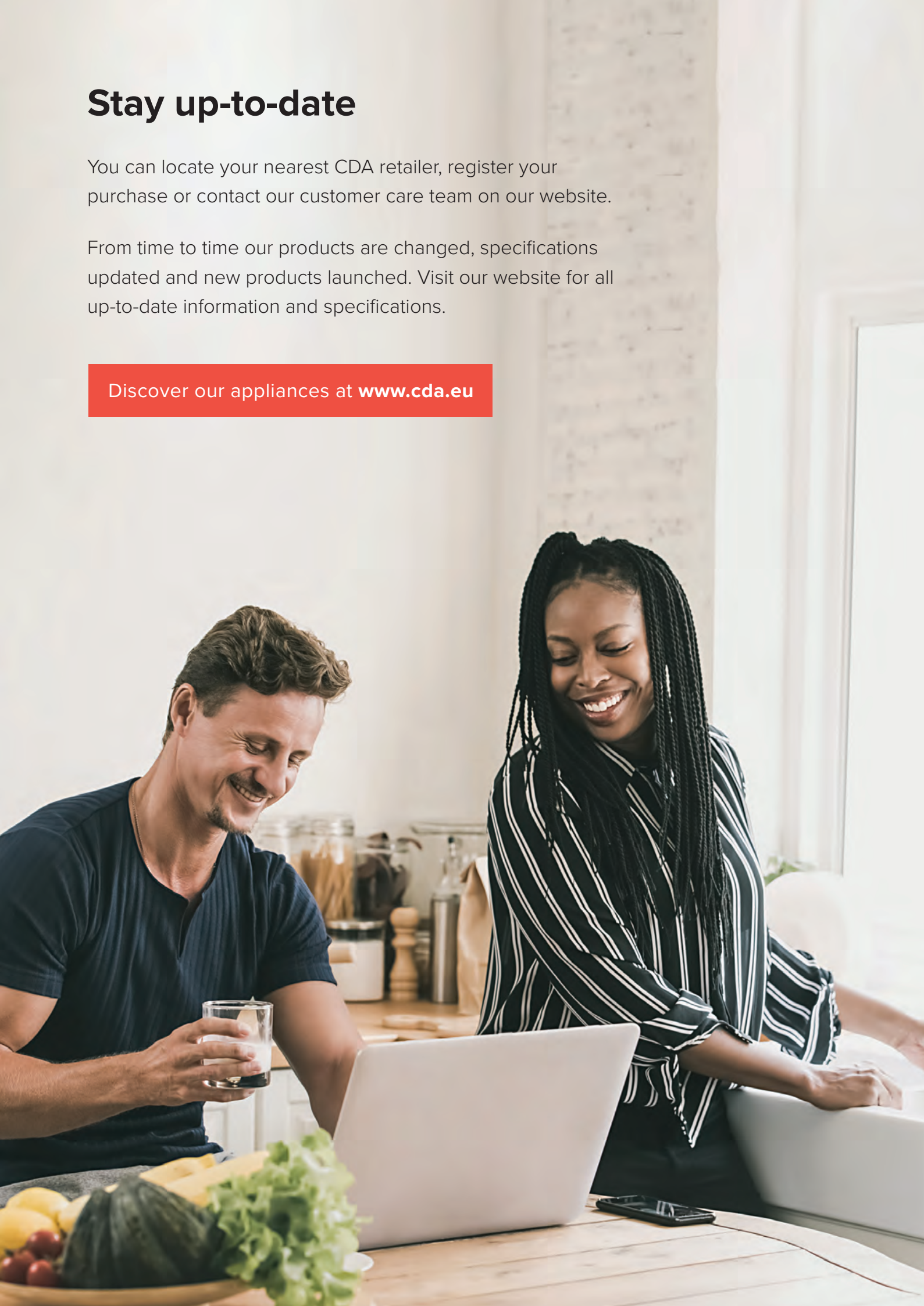

## Terms and conditions of guarantee

- Parts are defined as mechanical/electrical parts only.
- Products registered outside of the 30 day period will receive 12 months parts and labour.
- Proof of date of purchase must be supplied.
- To qualify for free parts they must be fitted by a CDA appointed engineer.
- Any attempts to modify or repair an appliance by an unauthorised person will render all guarantees invalid.
- A charge will be made for attending a reported fault that transpires to be due to misuse or mis-installation.
- CDA retains the right to invalidate the guarantee in the event of physical or verbal abuse towards any member of staff.
- CDA guarantees cover domestic use only - commercial use is not covered.
- Guarantees in whole or part are not transferable.
- Taps – during the first year, at our discretion we may pay for refitting (on receipt of the faulty part/tap, once inspected and deemed faulty) up to a maximum defined cost.
- The provision of services under the guarantee neither extends the term of the guarantee nor sets in motion a new guarantee period. The guarantee period for spare parts fitted ends with the expiry of the guarantee on the appliance as a whole. The guarantee remains effective from the date of purchase.
- On the occasion that a product is over 2 years old and is considered to be beyond repair, or uneconomical to repair, then we will offer a replacement appliance and charge an appropriate monetary offset in respect of the period of use already enjoyed.
- Guarantees apply in the UK and Southern Ireland only.



























### What is not covered

- Transport damage for which CDA is not responsible.
- Improper installation and assembly.
- Faults due to accidental damage or misuse.
- Gas leaks not related to a CDA appliance.
- Improper use including where an appliance has been used in a non-domestic environment, or poor maintenance, or failure to observe the operating instructions.
- Damage caused by the appliance coming into contact with unsuitable materials.
- Claims in respect of compensation for consequential loss, except where such liability is legally mandatory.
- Consumables and cosmetic parts such as glass, bulbs, seals, fuses, filters, external hoses, cosmetic parts, baskets, trays, burner caps, burner bases etc.
- Damage to, or during, the replacement of any light bulbs or removable parts of glass and plastic.
- TH102 3-in-1 instant hot water tap is guaranteed for 2 year parts and 2 year labour.

Details of extended warranties are available on request.

The table below shows where the guarantee is restricted due to non-domestic conditions:

	5 years parts, 2 years labour	2 years parts, 2 years labour	1 year parts, 1 year labour
Normal domestic sale and use	✓		
Rental or service apartment (non-students)		✓	
Students (communal living and non-communal), not new build		✓	
Students (communal living and non-communal), new build		✓	
Students (non-communal), one student per kitchen	✓		
Semi-commercial, e.g. school domestic science lab			✓

-  Oven light
-  Defrost
-  Conventional oven
-  Eco-conventional oven
-  Fan-assisted oven
-  Fan oven
-  Eco-fan oven
-  Fan cooking with lower heat
-  Fan cooking with upper heat
-  Fan with lower heat
-  Browning oven
-  Warming oven
-  Grill/half grill
-  Half-fanned electric grill
-  Fanned electric grill
-  Steam cooking
-  Eco-clean
-  Aqualytic cleaning function
-  Pyrolytic cleaning
-  Gas oven
-  Fanned gas oven
-  Microwave function
-  Microwave and grill function
-  Microwave and fan oven
-  Rapid preheat
-  Steam cleaning